

Lumistar Luminaire USL 05

- **For mounting on sight glass fittings:**
This sight glass luminaire is designed for universal applications. It is ideal for use in combined sight and light arrangements (single-flange version) or with two separate ports (2-flange version).

- **Compact design; powerful light output:**
Glare-free illumination; suitable for circular sight glass fittings to DIN 28120/DIN 28121 or similar, screw-type sight glass fittings in compliance with DIN 11851, and for visual flow indicators.

- **Generous light aperture and convenient lamp replacement thanks to optimally designed screwed lens closure.**

- **Application:**
For illuminating the interior of tanks, hoppers, silos, agitators and other, usually closed, vessels and reactors as well as visual flow indicators in **non-explosive environments**. Suitable for use in food processing industries.

- **Protection class:** dust- and splash-proof, IP 65 acc. to EN 60 529 / DIN VDE 0470, Part 1

- **Operating conditions:**
Independent of the internal pressure/vacuum in the vessel. On no account should a sight glass luminaire be used on its own to close a vessel port or as a replacement for the mating flange or instead of the complete sight glass flange assembly.

- **Maximum admissible ambient temperature at the cable entry gland with halogen version: 80°C**
When used in ambient temperatures exceeding 40°C and with halogen version, temperature-resistant cable such as Sinotherm 110 H05GG-F 3G 1.5 mm² should be used.

- **Very easy to install using special mountings, ensuring convenience of use:**
The luminaire is attached to the mating flange of the circular sight glass fitting or the visual flow indicator by means of a hinged bracket, or fastened to the grooved nut on screw-type sight glass fittings.

Lumistar luminaires USL 05 fit the following sizes:

- Circular sight glass fitting acc. to DIN 28120: from DN 25
- Circular sight glass fitting acc. to DIN 28121: from DN 40
- Visual flow indicators: from DN 25
- Screw-type sight glass fittings in compliance with DIN 11851:
 - DN 65, DN 80 are fastened using a separate flanged adapter
 - sizes DN 80 and up are secured by way of a hinged bracket

- **Voltage type:** AC/DC, depending on luminaire type

- **Operating voltage:**

without integrated transformer:

24 V	Halogen lamp	20 W, 50 W
120 V	Halogen lamp	50 W
230 V	Halogen lamp	25 W/50 W

with integrated transformer:

PTC-protected (5 W), otherwise thermal fuse (> 5 W)

120 V	Halogen lamp	12 V/5 W
230 V	Halogen lamp	12 V/5 W

CE

also available
in LED-technology

3755.175 h



Lumistar luminaire USL 05



Application as combined sight and light glass on a sight glass fitting acc. to DIN 28120, mounted using a hinged bracket

- **Transformers:**

Transformers for 24 V secondary voltage can be supplied on request.

• Dimensions and electrical data for Lumistar luminaire USL 05:

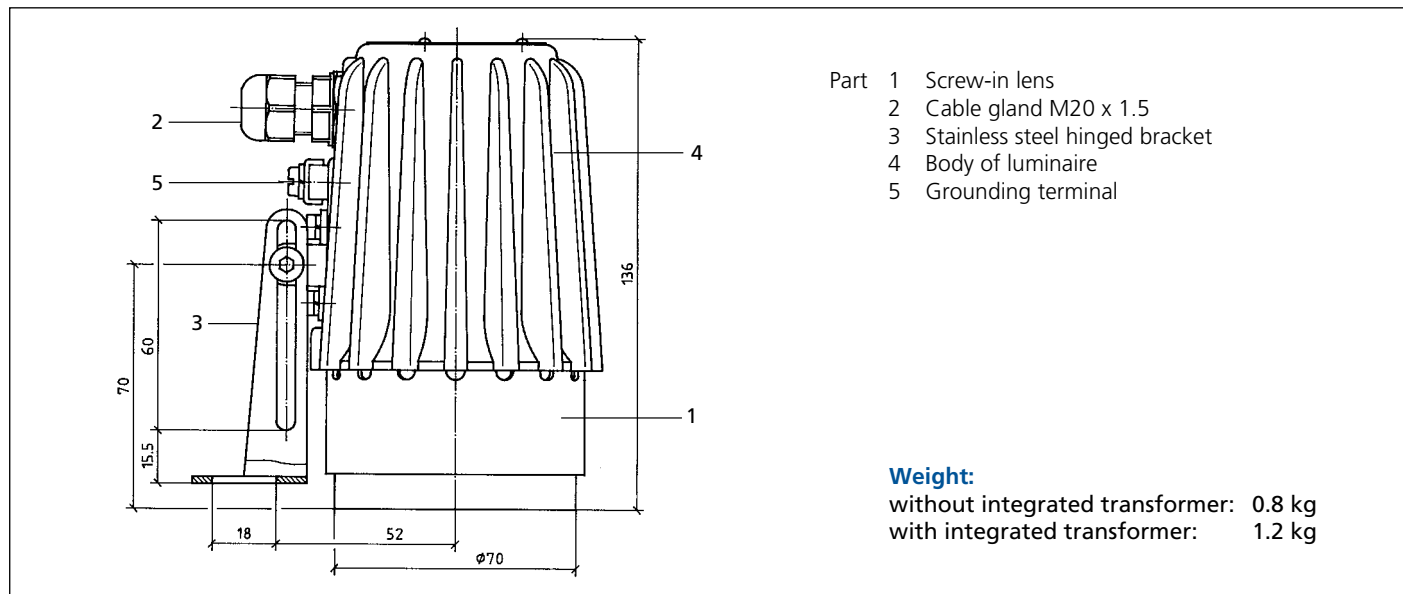

• Components and materials:

- Body of luminaire made of non-corrosive cast aluminium alloy, GK-ALSi10Mg
- Grounding terminal: The interior of the lamp is already fully wired; there is an additional grounding terminal on the outside of the housing
- Light aperture: Unit made of aluminium ring and glass with Viton seal
- Mounting parts: Stainless steel 1.4301 (see accessories)

• Connecting data:

Lumistar luminaire USL 05							Replacement halogen lamp		
No.	USL 05	Part no.	Nominal voltage V	Integrated transformer	Push-button	Timer	Voltage/wattage	Socket	Part no.
1	(230 V) 50 W	3540.068.00	230 ≈	without	with	without	230 V/50 W	GZ10	3232.261.00
2	(230 V/12 V) 5 W	3540.090.00	230 ~	with	with	without	12 V/5 W	G4	3232.221.00
3	(120 V/12 V) 5 W	3540.086.00	120 ~	with	with	without	12 V/5 W	G4	3232.221.00
4*	(24 V) 20 W	3540.093.00	24 ≈	without	with	without	Refl. 24 V/20 W	G4	3232.222.00
5	(24 V) 20 W	3541.941.00	24 ≈	without	with	without	24 V/20 W	G4	3232.206.00
6**	(24 V) 20 W	3540.094.00	24 ≈	without	without	without	Refl. 24 V/20 W	G4	3232.222.00
7	(24 V) 20 W	3541.942.00	24 ≈	without	without	without	24 V/20 W	G4	3232.206.00
8	(24 V) 20 W	3540.060.00	24 ~	without	with	with	24 V/20 W	G4	3232.206.00
9	(24 V) 50 W	3540.091.00	24 ≈	without	with	without	24 V/50 W	GY6.35	3232.242.00
10	(24 V) 50 W	3540.092.00	24 ≈	without	without	without	24 V/50 W	GY6.35	3232.242.00
11	(230 V) 25 W	3540.046.00	230 ~	without	with	with	230 V/25 W	G9	3232.276.00

* replaced by No. 5

** replaced by No. 7

• Accessories:

Item	Component	Part no.
1	hinged bracket for mounting luminaire, stainless steel	0354.014.00
2	flange adapter for mounting luminaire, stainless steel	1356.010.00
3	timer (external) for time-dependent illumination, Lumiglas timer push-button	on request
4	claw spanner for screw-in lens, for opening the luminaire	6816.001.00

• **Order data:** e.g. Lumistar luminaire USL 05, 24 V/20 W, part no. 3541.941.00, without integrated transformer, with pushbutton, without timer, with hinged bracket, part no. 0354.014.00

All dimensions in mm unless stated otherwise. Subject to change without prior notice. 07.17