

Installation and Operating Instructions

Lumistar Luminaires ASL 55-LED (alu) and ESL 55-LED (stainless steel)

Important, please note:

Sight glass luminaires are purpose-designed and intended solely for mounting on sight glass flange fittings. Under no circumstances should a sight glass luminaire be used to replace the cover flange or the entire sight glass flange fitting, nor should it be used on its own to cover an opening in a process vessel.

Caution: Do not look into light – danger of impaired eyesight!

General operating conditions:

- Independent of vacuum/pressure in the vessel
- Approved for use in ambient temperatures of between -20°C and +40°C
- Dust and waterjet proof, IP 65 to EN 60529/DIN VDE 0470 part 1

General electrical data:

- The feed voltage is converted to the operating voltage for the LED illuminant by a power board installed in the luminaire
- Voltage type: AC/DC
- The luminaire is equipped with an internal power board (see table).
- 10% admissible voltage tolerance

Mechanical installation:

Before commencing installation please refer to the information sheet 'Important guidelines for use of sight-glass fittings...'.
Lumistar luminaires ASL 55-LED and ESL 55-LED are suitable for the following nominal sizes with the appropriate fastening in each case:

Type of fitting	from DN	Hinged bracket	Flanged adapter
Circular sight glass fitting			
DIN 28120	40	+	-
DIN 28121	40	+	-
Visual flow indicator	50	+	-
Screw-type sight glass fitting	50	-	+
	65	-	+
similar to DIN 11851	80	+	+
	100	+	+
	125	+	+

Mounting by way of hinged bracket:

The hinged bracket is used to secure the luminaire to the cover flange of a circular sight glass fitting (also suitable for visual flow indicators). Alternatively, it can be attached to the slotted cover nut of screw-type sight glass fittings to DIN 11851.

The hinged bracket is fixed in place by turning the supplied M8 bolt into a blind hole which has previously been tapped in the pitch circle of the cover flange face. An additional opening is to weld on the bracket.

Mounting by way of flanged adapter collar:

The flanged adapter is mounted using the slotted cover nut (DIN 11851):

- Place a suitable seal between the glass lens and the flanged adapter collar.
- Position the slotted cover nut and tighten.
- Insert the luminaire into the flange and secure.
- Please note: The Lumistar luminaire variant for sterile engineering applications is fitted over the adapter collar of the special flange for sterile technology.
- Tighten the retention screws at the side.



Lumistar luminaire ASL 55-LED

ASL 55-LED/ ESL 55-LED Type variant	Nominal voltage Volt	Internal power board
(24 - 48 V) 11 W	24 - 48 ≈	1 A
(120 - 230 V) 11 W	120 - 230 ≈	1 A
(24 V) 15 W	24 ≈	1 A + 1,6 A
(120 - 230 V) 15 W	120 - 230 ≈	1 A

Luminaire with special accessories (dimmer/timer):

1. Push-button function:

The luminaire is switched on and off by pressing the button once

2. Dimmer function:

- Switch on the luminaire by pressing the button
- Press the button and hold it depressed (the brightness will change)

- Release the push-button when the required light intensity has been reached.

This setting will be automatically saved.

Please note: the luminaire will flash once the maximum and minimum brightness levels have been reached.

3. Timer function:

In its delivery state, the luminaire is equipped with a works-fitted activated timer

- Push the button

The timer is automatically activated. The luminaire switches off by itself once the preset period of time has expired. If the dimmer function is used during the programmed period, the time set on the timer will restart once the push-button is released.

- The run time can be interrupted by pressing the button again.

Activating/deactivating the timer function

- The timer is activated or deactivated by pressing the button and at the same time applying or switching on the mains voltage.

The current state of the luminaire is shown by

Flashing once = timer off

Flashing twice = timer on

Lumiglas

• Electrical connection:

- The cable entry gland is suitable for inserting all types of unarmoured cable; the outer sheath of the cable is sealed by the cable entry gland.

Choose an appropriate connection cord which is suitable for the operating conditions and fits the cable entry gland (M20 x 1.5) (part 1), \varnothing 6-12 mm.

The ferrite core included in the scope of supply must be used for connecting the luminaire. All connecting wires must be wound a complete turn around the core (photos: e.g. 230 V). When using the 24-V version, the ferrite core should be slid onto the cable 10 mm from the cover.

• Information about protection of integrated electronics:

The luminaire is equipped with a thermostat as protection for the electronic components. Once the thermostat has been activated by excess temperature or incorrect mains voltage, it is not possible to switch the luminaire on. If this happens, an appropriate cooling period should be allowed.

When using 24 V mains power supply, the parallel connection of luminaires with only one feed line should be avoided. The resulting major impedances in the feed line due to the reduced line cross-section together with contact resistances caused by terminals and connectors can lead to malfunctions in the luminaire.

• Please note:

Fastening elements should be ordered separately if required.

• Replacement parts:

End cover

Aluminium

Stainless steel

Light port lens (light aperture)

Aluminium

Stainless steel

Cable entry gland ASL 55-LED/ESL 55-LED

O-ring seal

Grub screw

Cylinder head screw M4x12 A2-70

Cylinder head screw M4x25 A2-70

Part No.

0821.012.00

0821.011.00

1773.014.00

1773.015.00

9103.122.00

0862.090.00

7446.075.00

6911.358.00

6911.359.00

• Servicing:

- The luminaire should be kept clean.

- After opening the luminaire, clean the surfaces of the cylindrical gap between the end cover (5) and the light port lens (6). Before re-assembling the luminaire, check these components for any damage and relubricate them (e.g. with AEMA-SOL 6B, by A.E. Matthes).

- Please use original replacement parts only.

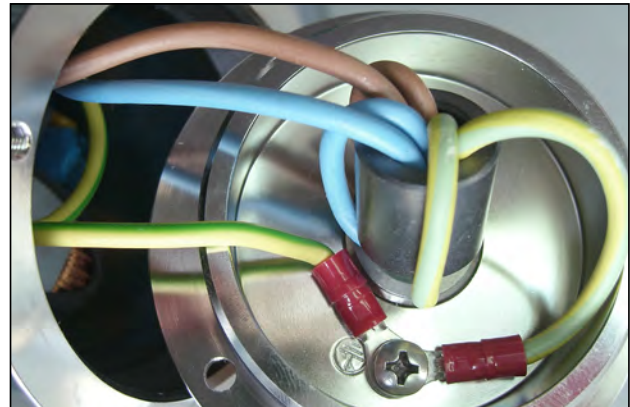
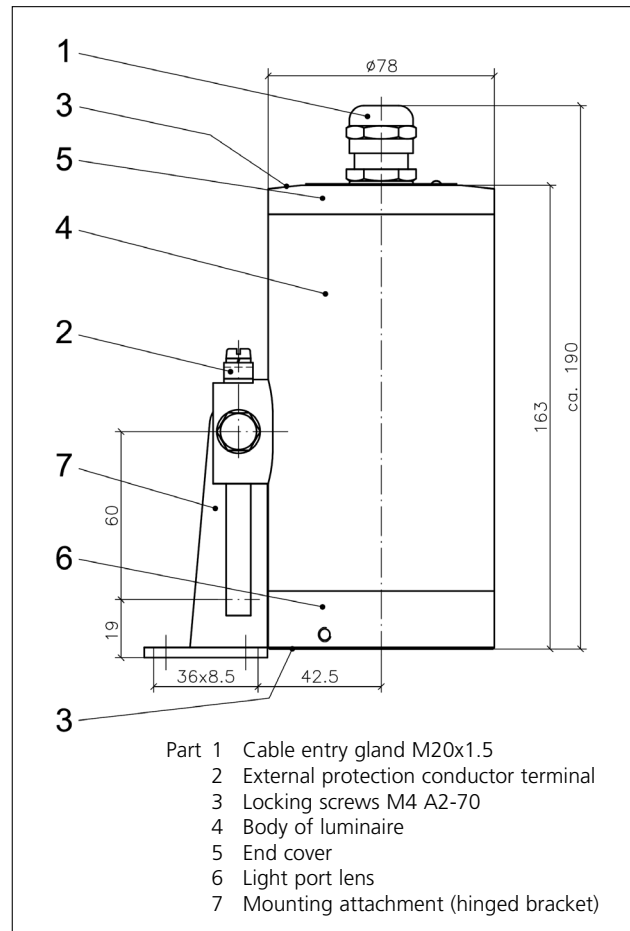

Variant 230 V

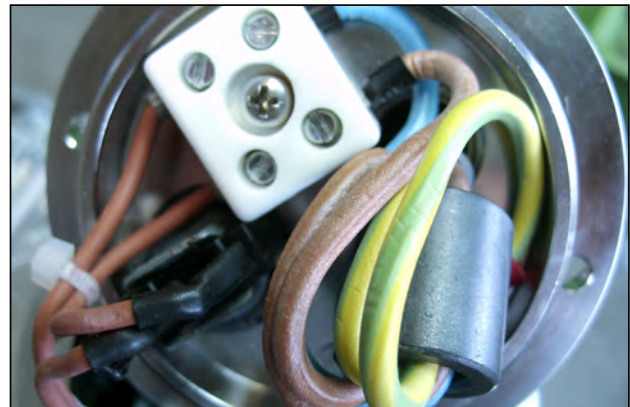

Variant with push button

All dimensions in mm unless stated otherwise. Subject to change without prior notice. 07.17