

Installation and Operating Instructions **CE**

0093.080.00 b

Lumistar Luminaire ESL 25, Stainless Steel

Important note:

Sightglass luminaires are specifically and solely designed for mounting on top or side of sightglass units. Never use a luminaire in place of mating flange or complete sightglass unit to provide a closure for an opening in a process vessel. On no account may the luminaire be used as a closure/ means of sealing of a (pressure) vessel i.e. without a suitable sightglass fitting.

Operating conditions – general:

- Independent of vessel internal pressure/vacuum
- Max. ambient temperatures at cable entry gland: 80°C
- At ambient temperatures > 40°C, high temperature cable must be used, e.g. Sinotherm 110 H05GG-F 3G 1,5 mm²
- Protection: Dust- and waterjet tight IP 65 to EN 60529/DIN VDE 0470 part 1.

Electrical data – general:

- The voltage, power and IP rates are shown on the type plate
- The version with integrated transformer is PTC protected, no fuse replacement necessary
- Voltage type: AC/DC, depending on the luminaire set-up

Caution: Luminaires with an integrated transformer or high-voltage timer must be operated with AC voltage!

Caution: Overvoltage will cause premature lamp failure!

Electrical connection:

- The flared cable entry is designed for use with non armoured cable and utilizes the resilient outer coating of the cable to make the seal
- Select a suitable cable to suit operating conditions and a cable diameter to match entry gland (M20x1.5): where ambient temperature > 40°C, heat resistant cable must be used (1)
- Using correct tool, loosen and unscrew lens ring unit (3), see 'Lamp exchange'
- Loosen cable gland (1)
- Pass cable through gland (1) into lamp body and secure cores to terminals
- Tighten gland (1)
- Refit and tighten lens ring unit (3) until firm seal is made, see 'Lamp exchange'

Lamp exchange:

- Switch off power
- Using correct tool (lens ring pag spanner), unscrew lens ring (3)
- Pull out defective (2 pin) lamp
- Holding new lamp (use only recommended parts) with its protective material, insert carefully into 2 pin socket and push in firmly
- Replace and tighten lens ring (3) until seal is made (O ring squeezed)
- Switch on power



Lumistar luminaire ESL 25, stainless steel

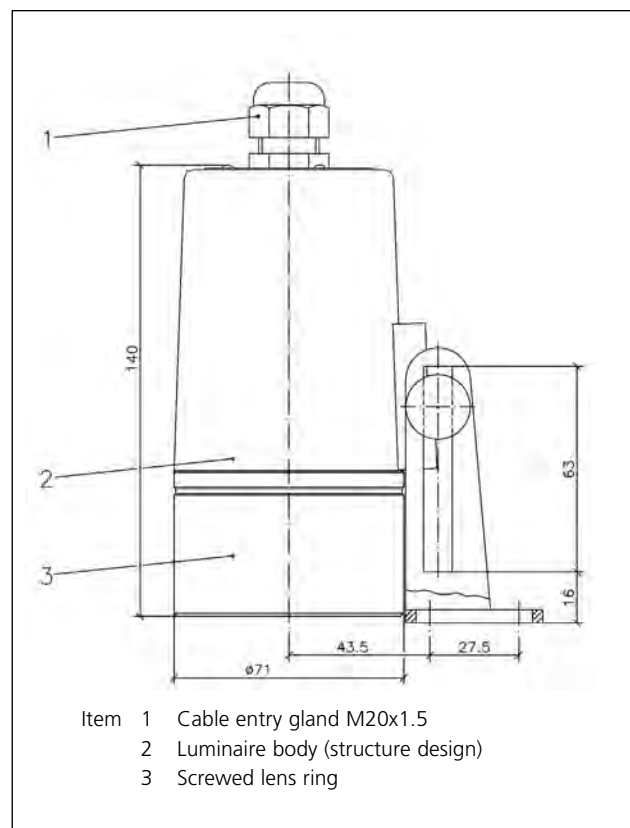

• **Mechanical installation:**

The Lumistar luminaire ESL 25 is suitable for sight glasses in the following nominal sizes, using the appropriate mounting:

Type of fitting	from DN	Hinged bracket	Flanged ad. collar
Circular sightglass fitting DIN 28120 DIN 28121	25	+	-
	40	+	-
Flow indicator	50	+	-
Screwed sightglass fitting DIN 11851	65	-	+
	80	+	-
	100	+	-
	125	+	-

• **Mounting with hinged bracket:**

The hinged bracket serves to secure the luminaire to the mating flange of a circular sightglass unit (also of a flow indicator) or the slotted cover nut of screwed sightglass similar to DIN 11851.

The bracket is fixed using the M8 screw supplied and a blind hole drilled and tapped on the bolt pitch circle of the cover flange face. Alternatively the bracket can be welded on.

• **Mounting with flanged adapter collar:**

The adapter fits between glass disc and the slotted cover nut (DIN 11851):

- Place gasket provided between glass face and adapter collar
- Tighten slotted cover nut
- Slide luminaire into adapter sleeve and tighten radially located grub screws
- **Note:** The version of the Lumistar luminaire for use in sterile technology is seated firmly in a specially formed lip in the mating flange, sealed and clamped to the light by means of an 'O' ring!
- **Note:** Mounting bracket, peg spanner etc. – if not available – should be ordered separately!

• **Servicing:**

- Keep luminaire clean
- After opening luminaire, lightly grease the lens ring (3) thread (e. g. with AEMA-SOL 6 B, made by A. E. Matthes)
- Allow for average lamp life span!
- Use only original replacements parts!

• **Replacement parts:**

Item	Description	Part -.
1	Hinged bracket	0354.019.00
2	Adapter flange	1356.010.00
3	Lens ring/claw spanner	6816.001.00
4	Lens ring unit (light outlet with reflector)	1774.063.00
5	Lens ring unit (light outlet without reflector)	1774.062.00
6	O ring seal (Viton)	0862.073.00
7	Lamp socket G 4	1202.011.00
8	Lamp socket GU 4	1202.023.00
9	Lamp socket GY 6.35	1202.012.00
10	Cable entry gland M20x1.5	9103.101.00
11	Halogen filament lamp 12 V, 5 W	3232.224.00
12	Halogen filament lamp 12 V, 10 W	3232.221.00
13	Halogen filament lamp 12 V, 20 W	3232.229.00
14	Halogen filament lamp (cold light) 12 V, 20 W	3232.221.00
15	Halogen filament lamp 24 V, 20 W from construction year 07.2017	3232.206.00
16	Halogen filament lamp 24 V, 20 W	3232.222.00
17	Halogen filament lamp 120 V, 20 W	3232.267.00
18	Halogen filament lamp (cold light) 12 V, 35 W	3232.232.00
19	Halogen filament lamp (cold light) 12 V, 50 W	3232.238.00
20	Halogen filament lamp (cold light) 24 V, 50 W	3232.242.00
21	Halogen filament lamp (cold light) 120 V, 50 W	3232.265.00