

Lumistar Luminaire ESL 25-Ex, Stainless Steel

CE 0158

3755.194 c



II 2G Ex d IIC T4/T6 Gb
II 2D Ex tb IIIC T80/T130°C Db

- **For mounting on sight glass fittings**
Designed for universal applications, this Ex-type sight glass luminaire has been developed for use in potentially explosive environments. It is ideal for combined sight glass and light assemblies, either as a single-flange version or with two separate flanged ports.
- **Compact yet powerful:**
Dazzle-free illumination, for use with circular sight glass fittings to DIN 28120/DIN 28121 or similar, with screwed sight glass units in compliance with DIN 11851, and in visual flow indicators.
- **Large light aperture and convenient lamp replacement thanks to optimised screw-in lens design.**
- **Application:** For illuminating visual flow indicators, pipelines, laboratory mixers, bioreactors as well as the interior of pressure vessels, tanks, agitators and other – normally closed – processing vessels in **potentially explosive environments**.
Gas: Zones 1 and 2; Dust: Zones 21 and 22.

- **Particularly suitable for use in sterile environments.**

- **Protection:** IP 65 und IP 67 nach DIN EN 60529

- **Operating conditions:** Independent of the internal pressure/ vacuum in vessel. Under no circumstances should a sight glass luminaire be used to replace the mating flange or the sight glass/ luminaire assembly or on its own to close a vessel port.

- **Lumistar luminaires of this type are approved for use in ambient temperatures of up to 60°C, depending on the lamp bulb fitted.**

- **Technical data Ex protection:**

This luminaire meets the essential safety and health requirements by complying with the regulations for

a) Gas

EN 60079-0: 2009 General Requirements
EN 60079-1: 2007 Flame-proof Enclosure 'd'
Explosion group: IIC (includes II A and II B)
Temperature class: up to T6 (depending on wattage)

b) Dust

EN 00079-0: 2009 General Requirements
EN 60079-31: 2009 Protection by Enclosures 't'
Explosion group: IIIC (includes III A and III B)
Temperature class: T80/T130°C (depending on wattage)

- **EC type-examination certificate:** BVS 08 ATEX E 137



II 2G Ex d IIC T4/T6 Gb
II 2D Ex tb IIIC T80/T130°C Db

- **Voltage type:** AC/DC, depending on lamp

- **Operating voltage:**

without integrated transformer:

12 V... Halogen lamp 5 W, 10 W, 20 W
24 V... Halogen lamp 20 W

with integrated transformer:

120 V... Halogen lamp 12 V/5 W/10 W
230 V... Halogen lamp 12 V/5 W/10 W
5 W = PTC protection, 10 W = thermal fuse

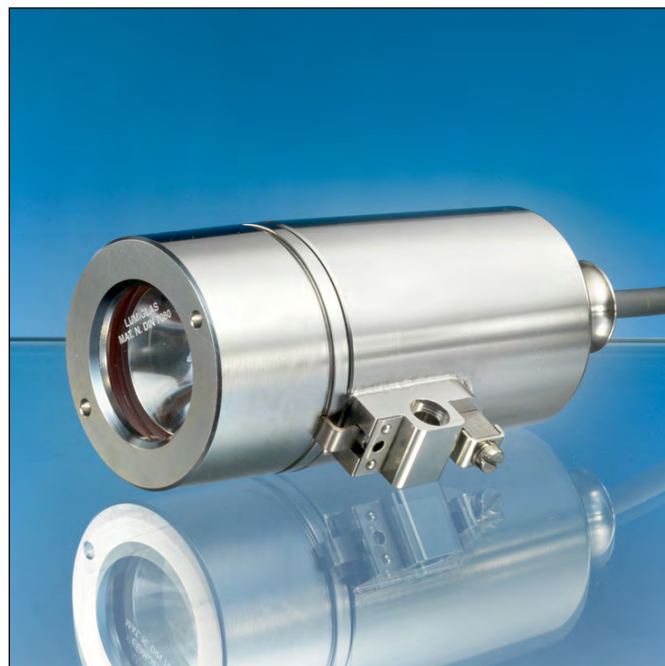

Lumistar luminaire ESL 25-Ex, stainless steel

- **Straightforward electrical connection via integrated cable tail or Ex d cable entry gland.**

- **Electrical connection**

Connecting cable options:

- Works-fitted cable tail (2 m standard length), resin cast into trumpet cable entry gland, heat-resistant up to 110°C.
5 m, 10 m and 20 m lengths are also available.
- Without works-fitted cable: connecting cable to fit the cable entry gland (M20 x 1.5) to be provided by operating company.

If ambient temperatures are greater than 40°C, heat-resistant cable, e. g. Sinotherm 110 H05GG-F 3G 1.5 mm² should be used.

- **Mounting options:**

With circular sight glass fittings and flow indicators the luminaire is secured to the mating flange by means of the hinged bracket. With screw-type sight glass units the luminaire is mounted on the slotted cover nut.

The Lumistar luminaire ESL 25-Ex fits the following nominal sizes:

- Circular sight glass fittings to DIN 28120: from DN 50
- Circular sight glass fittings to DIN 28121: from DN 40
- Flow indicators: from DN 50
- Screwed sight glass units in line with DIN 11851:
 - With DN 65, mounting is by way of separate flange adapter collar
 - From DN 80 up, the hinged bracket is used

- **For sterile applications, a version of this Lumistar luminaire is available with a sleeve that fits over a raised lip on the mating flange.**

• **Dimensions and electrical data for Lumistar luminaire ESL 25-Ex:**

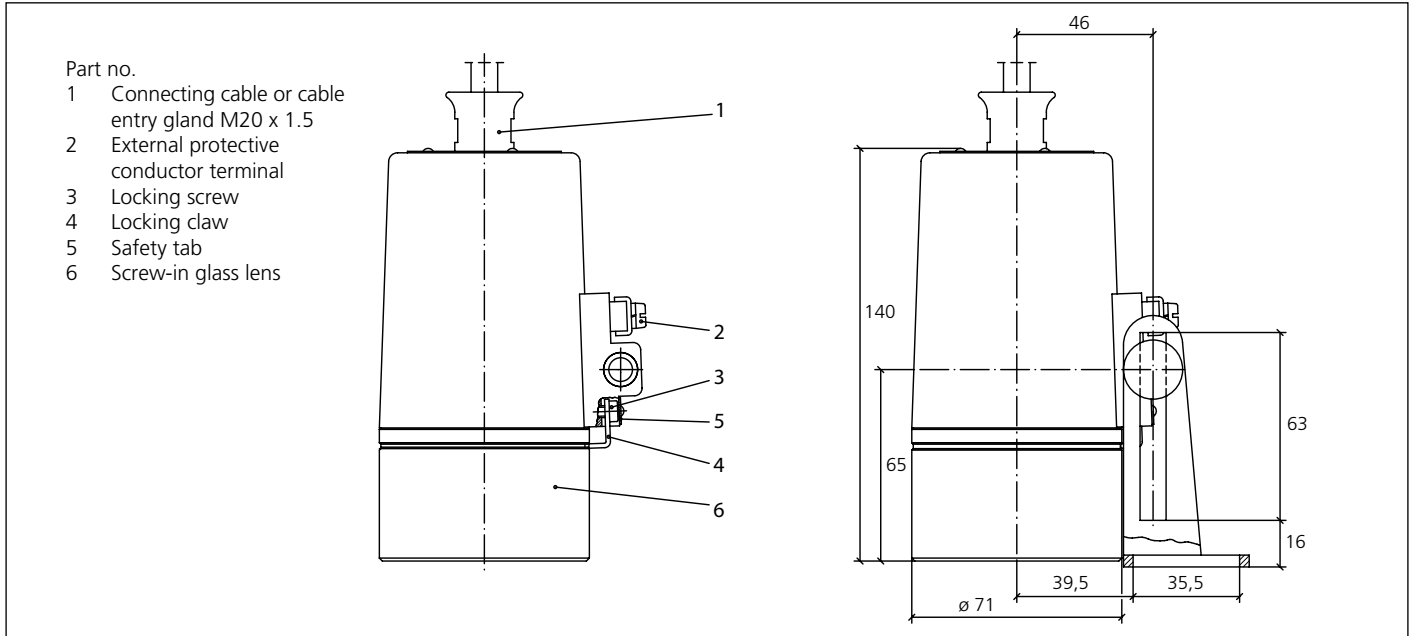

• **Components and materials:**

- Body of luminaire: Stainless steel 1.4404, polished
- Fastening components: Stainless steel 1.4301 (see 'Accessories')
- Cable entry gland: M20 x 1.5

• **Weight (without connecting cable):**

- without integrated transformer: 1.8 kg
- with integrated transformer: 2.2 kg

• **Connecting data: Temperature classification and electrical parameters (see also EC Type-Examination Certificate)**

No.	ESL 25-Ex Variant	Part No. ESL 25-Ex with connecting cable	Voltage Volt	Integr. transformer	Halogen lamp		Ambient temperature range			
					Socket	Voltage/wattage	$-20^{\circ}\text{C} \leq T_a \leq +40^{\circ}\text{C}$		$-20^{\circ}\text{C} \leq T_a \leq +60^{\circ}\text{C}$	
1	(12 V) 5 W	3540.902.00	12 \approx	without	G4	12 V/5 W	2G T6	2D T80°C	-	-
2	(120 V/12 V) 5 W	3540.904.00	120 \sim	with	G4	12 V/5 W	2G T6	2D T80°C	-	-
3	(230 V/12 V) 5 W	3540.906.00	230 \sim	with	G4	12 V/5 W	2G T6	2D T80°C	-	-
4	(12 V) 10 W	3540.907.00	12 \approx	without	G4	12 V/10 W	2G T4	2D T130°C	2G T4	2D T130°C
5	(120 V/12 V) 10 W	3540.908.00	120 \sim	with	G4	12 V/10 W	2G T4	2D T130°C	2G T4	2D T130°C
6	(230 V/12 V) 10 W	3540.910.00	230 \sim	with	G4	12 V/10 W	2G T4	2D T130°C	2G T4	2D T130°C
7	Cold-light (12 V) 20 W	3540.912.00	12 \approx	without	GU4	12 V/20 W	2G T4	2D T130°C	-	-
8	(12 V) 20 W	3540.914.00	12 \approx	without	G4	12 V/20 W	2G T4	2D T130°C	-	-
9*	(24 V) 20 W	3540.916.00	24 \approx	without	G4	Reflector 24 V/20 W	2G T4	2D T130°C	-	-
10	(24 V) 20 W	3540.919.00	24 \approx	without	G4	24 V/20 W	2G T4	2D T130°C	-	-

* replaced by No. 10

• **Accessories:**

No.	Component	Part no.
1	Hinged bracket mounting for luminaire	0354.019.00
2	Flanged adapter collar mounting for luminaire	1356.010.00
3	Mounting for sterile applications for luminaire without integrated reflector	1774.050.00
4	Mounting for sterile applications for luminaire with integrated reflector	1774.051.00
5	Peg spanner for screw-in lens	6816.001.00
6	Timer module, Ex version	on request
7	Connecting cable	on request

• **Order data:** e. g.

- Lumistar luminaire ESL 25-Ex (230 V/12 V) 5 W, Ex d IIC T6 with 2 m connecting cable, part no. 3540.906.00

All dimensions in mm unless stated otherwise. Subject to change without prior notice. 07.17