

Installation and Operating Instructions 0158

0093.120.00 a

Lumistar Luminaire ASL57LED-Ex, Aluminium

 II 2G Ex d(e) IIC T6 Gb
II 2D Ex tb IIIC T80°C Db

• Important, please note:

Sight glass luminaires are purpose-designed and intended solely for mounting on the top or side of sight glass flange fittings. Under no circumstances should a sight glass luminaire be used to replace the cover flange or the entire sight glass flange fitting, nor should it be used to cover an opening in a process vessel. Luminaires for potentially explosive areas must be mounted, connected and serviced by qualified personnel who have been specifically trained and authorised to do this work. The data set out in the EC type examination certificate must be complied with! Caution: Do not look into light – danger of impaired eye sight.

• General operating conditions:

- Independent of vacuum/pressure in the vessel
- Approved for use in potentially explosive (Ex) areas:
- Gas: zones 1 and 2; dust: zones 21 and 22
- **Approved for use in ambient temperatures of between -20°C and +40°C**

• General electrical data:

- The voltage, power, temperature class and protection class are shown on the type plate
- Ex approval acc. to EC type examination certificate: BVS 14 ATEX E 122 X

 II 2G Ex d(e) IIC T6 Gb
II 2D Ex tb IIIC T80°C Db

- The feed voltage is converted to the operating voltage for the LED illuminant by way of a power board installed in the luminaire
- Voltage type: AC/DC
- The luminaire is protected at 230 V by a 1 A miniature fuse on the internal power board and at 24 V by a 2.5 A miniature fuse.
- 10% admissible voltage tolerance

• Mechanical installation:

The Lumistar luminaire ASL57LED-Ex is suitable for the following nominal sizes with the appropriate fastening in each case:

Type of fitting	from DN	Hinged bracket	Flanged adapter
Circular sight glass fitting			
DIN 28120	100	+	-
DIN 28121	100	+	-
Flow indicator	50	+	-
Screw-type sight glass fitting based on DIN 11851	65	-	+
	80	+	+
	100	+	+
	125	+	+

• Parameters/temperature classification:

ASL57LED-Ex Variant	Nominal voltage Volt	Ambient temperature range -20°C ≤ T _a ≤ +40°C	
(24 V) 35 W	24 ≈	2G T6	2D T80°C
(120 - 230 V) 35 W	120 - 230 ~	2G T6	2D T80°C



Lumistar luminaire ASL57LED-Ex with connecting cable (variant I)

• Mounting with hinged bracket:

The hinged bracket is intended for attaching the luminaire to the cover flange of a circular sight glass fitting (or a sight glass in a flow indicator), or to the slotted cover nut on a screw-type sight glass fitting to DIN 11851.

The hinged bracket is secured to the port of a circular sight glass fitting using the M8 screw included in the scope of supply. A blind hole needs to be provided in the circumference for this purpose.

Alternatively, the hinged bracket can be welded in place.

• Mounting with flanged adapter collar:

The luminaire is inserted into the welded-on flange of the slotted nut and secured with the screws.

• Please note:

Please order any required mounting parts separately.

• Warning:

The body of the luminaire and the connection cover should not be interchanged with other parts of this series.

• Electrical connection – Variant I:

a) ASL57LED-Ex with connecting cable

- The connecting cable has already been works-fitted to the luminaire so that it is ready for use.
- The external protective conductor (3) must be connected to a separate operational earth.
- The connecting cable needs to be secured after max. 1 m.
- When replacing the cable, the internal terminals must be loosened before the cable entry gland can be unscrewed.

Conditions/requirements:

Ex-type luminaires are manufactured with a permanently connected cable. The free ends of the cable must be installed in a category 2G/2D enclosure if it is connected in a potentially explosive environment. Prior to installation or during servicing work on the luminaire, the area surrounding the place of installation and the luminaire should be cleared of dust. The dismantled parts should be protected against dust and dirt while installation or servicing work is in progress. Before closing the luminaire, make sure that the interior of the lamp is free of dust.

When using 24 V mains power supply, the parallel connection of luminaires with only one feed line should be avoided. The resulting major impedances in the feed line due to the reduced line cross-section together with contact resistances caused by terminals and connectors can lead to malfunctions in the luminaire.

With connection variants (24 V) b and c the ferrite core included in the scope of supply should be used. All the connecting wires need to be wound a full turn around the core in the enclosure:

b) ASL57LED-Ex with cable entry gland (encapsulated)

- Select a connecting cable to fit the M20x1.5 cable entry, taking due consideration of the diameter of the cable (6.7-10.3 mm)
- The minimum temperature resistance of the connecting cable must be observed (-20°C/+85°C).

c) ASL57LED-Ex (tested combination)

Only the following cable entry glands and cables should be combined:

Cable gland types	Installation torque	
	7.0	2.5
HSK-M-Ex-d, part no. 9103.123.00 M20x1.5 nickel-plated brass (by Hummel)	7.0	2.5
KU1BPM20-Ex-d-Alpha X part no. 9103.130.00 M20x1.5 nickel-plated brass (by RST)	6.0	3.0

Cable types
EVA flexible sheathed cable, Sinotherm 110, part no. 3403.017.00, 3x1.5 qmm, ø 8.5 mm
Ölflex Heat 180, part no. 3403.045.00 3x1.5 qmm, ø 8.9 mm
Ölflex Heat 180, Silflex UR-AWG18, part no. 3403.044.00 5x1.0 qmm, ø 10.3 mm
Ölflex Classic 110 Black, part no. 3403.051.00 3x1.5 qmm, ø 10.1 mm

Variant II: ASL57LED-Ex with terminal box

Guide the connecting cable through the Ex e cable entry gland into the terminal box and wire them to the terminals.

- **Caution:** The locking screws for the connection cover (M4x12) and light port lens (M5x16) must have a yield strength of $\geq 240 \text{ N/mm}^2$ (A2-70). The tightening torques for the screws are as follows: 0.8 Nm for M4x12 and 1.3 Nm for M5x16.

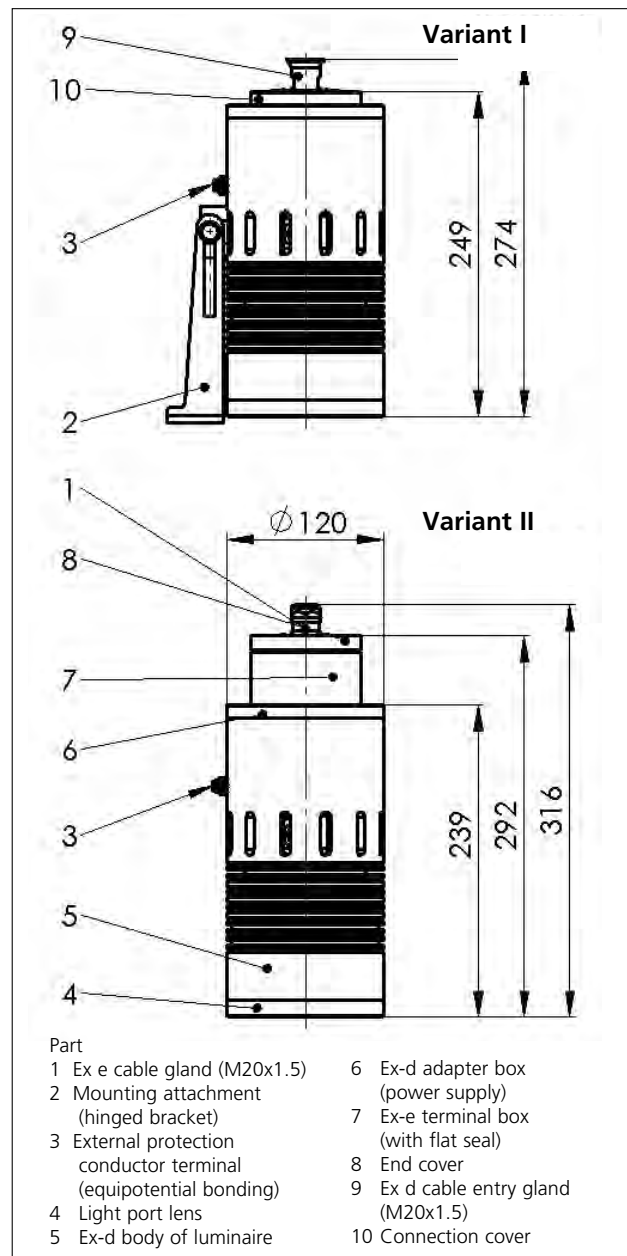

• Warning:

The body of the luminaire and the connection cover should not be interchanged with other parts of this series.

• Replacement parts:

	Part no.
Connection cover	0821.023.00
Light port lens (light aperture)	1773.018.00
Cable entry gland (Ex d M20x1.5) nickel-plated brass	9103.129.00
O-ring seal Ø 94x1.5	0862.099.00
O-ring seal Ø 65x1.5	0862.098.00
Grub screw	7446.075.00
Cylinder head screw M4x12 A2-70	6911.358.00
Cylinder head screw M5x16 A2-70	6911.362.00

• Servicing:

- Keep the luminaire clean.
- After opening the luminaire, the surfaces of the cylindrical gap between the connection cover (10) respectively the terminal box (7) and the light port lens (4) should be cleaned. Before re-assembling the luminaire, check these components for any damage and relubricate them (e.g. with AEMA-SOL 6B, by A.E. Matthes).
- Please use original replacement parts only.

All dimensions in mm unless stated otherwise. Subject to change without prior notice. 07.17