

Installation and Operating Instructions 0158

0093.033.00 c

Lumistar Luminaire Stainless Steel ESL 25-Ex

 II 2G Ex d IIC T4/T6 Gb
II 2D Ex tb IIIC T130/T80°C Db

• Important, please note:

Sight glass luminaires are specifically designed and solely intended for mounting with or onto flanged sight glass fittings. Under no circumstances should sight glass luminaires be used as a substitute for the mating flange or the complete sight/light port or as a lid or cover for vessel openings. Luminaires for use in potentially explosive environments must be mounted, installed and serviced by staff who have the relevant qualifications and have been properly trained for this type of work. **Please observe the data set out in the EC type-examination certificate!**

• General operating conditions:

- Independent of pressure/vacuum in the vessel
- Approved for use in Ex environments:
Gas: Zones 1 and 2; Dust: Zones 21 and 22
- **Approved for use in ambient temperatures of between -20°C and +60°C or +40°C, depending on the lamp power (see type plate and temperature classification parameters).**

• Electrical data, general:

- Voltage, power, temperature class and protection rating are shown on the type plate.
- Ex approval acc. to EC type-examination certificate: BVS 08 ATEX E 137
 II 2G Ex de IIC T4/T6 Gb
II 2D Ex tb IIIC T130/T80°C Db
- The variant with integrated transformer is PTC-protected with 5 W; thermal link with 10 W.
No fuse replacement necessary.
- Power supply: AC or DC, depending on lamp fitted
- **Caution:** Only alternating current should be used on luminaires with integrated transformer.
- **Warning:** Over-voltage will cause premature lamp failure!
- 10% voltage tolerance is admissible.

• Mechanical installation:

The Lumistar luminaire ESL 25-Ex fits the following nominal sizes using the appropriate fastenings in each case:

Type of fitting	from DN	Hinged bracket	Flanged adapter collar
circular sight glass fitting DIN 28120	25	+	-
	40	+	-
DIN 28121	50	+	-
Visual flow indicator	65	-	+
Screw-type sight glass fitting similar to DIN 11851	80	+	-
	100	+	-
	125	+	-

• Parameters/Temperature classification:

ESL 25-Ex Variant	Nominal Voltage	Ambient temperature range			
		-20°C ≤ T _a ≤ +40°C		-20°C ≤ T _a ≤ +60°C	
(12 V) 5 W	12 ≈	2G T6	2D T80°C	-	-
(120 V/12 V) 5 W	120 ~	2G T6	2D T80°C	-	-
(230 V/12 V) 5 W	230 ~	2G T6	2D T80°C	-	-
(12 V) 10 W	12 ≈	2G T4	2D T130°C	2G T4	2D T130°C
(120 V/12 V) 10 W	120 ~	2G T4	2D T130°C	2G T4	2D T130°C
(230 V/12 V) 10 W	230 ~	2G T4	2D T130°C	2G T4	2D T130°C
Cold-light reflector lamp (12 V) 20 W	12 ≈	2G T4	2D T130°C	-	-
(12 V) 20 W	12 ≈	2G T4	2D T130°C	-	-
Reflector-3540.916.00-*(24 V)-20-W	24 ≈	2G-T4	2D-T130°C	-	-
3540.919.00 (24 V) 20 W	24 ≈	2G T4	2D T130°C	-	-

* replaced by 3540.919.00



Application as combined sight and light port on a sight glass fitting acc. to DIN 28120, mounting by way of hinged bracket

• Mounting with hinged bracket:

The hinged bracket is used to secure the luminaire to the mating flange of a circular sight glass unit (also suitable for flow indicators). Alternatively, it can be attached to the slotted cover nut of screw-type sight glass fittings to DIN 11851.

The bracket is fixed in place by turning the supplied 'M8' bolt into a blind hole which has previously been tapped in the pitch circle of the mating flange face. An additional option is to weld the bracket on.

• Mounting with flanged adapter collar:

The flanged adapter collar fits between the glass disk and the slotted cover nut (DIN 11851):

- Position appropriate seal between glass face and the flanged adapter collar
- Tighten the slotted nuts
- Insert the luminaire into the flanged collar
- **Please note:** The Lumistar luminaire variant for sterile technology is slipped over the collar of the sterile technology flange.
- **Please note:** Please order fastening and mounting elements, claw spanner, etc. separately if not available.

• **Electrical connection:**

a) **ESL 25-Ex with cable tail**

- The cable tail is already works-fitted in the luminaire and is ready for use.
- The external protective terminal (2) must be separately earthed.
- The cable tail should be supported after max. 1 metre.
- Caution! When replacing the cable (e. g. by one with a different length), ensure the internal connections have been loosened prior to unscrewing the cable gland.

Special operating conditions:

Ex-category luminaires have been manufactured with a fixed connecting cable.

If the terminals are in a potentially explosive environment, the free ends of this cable must be installed in a flameproof housing category (2G/2D). Prior to installation and whenever the luminaire is being serviced, please remove all dust from the luminaire and from the area surrounding the place of installation.

The dismantled parts should be protected against dust and dirt during all installation or maintenance work.

When closing the luminaire, please take special care to ensure that the interior of the luminaire is free of dust.

b) **ESL 25-Ex with cable entry gland**

- Select an M20 x 1.5 connecting cable to fit the cable entry gland.
- If ambient temperatures are greater than 40°C, heat-resistant cable, e. g. Sinotherm 110 H05GG-F3G 1.5 mm² should be used.
- The minimum heat resistance of the connecting cable is specified on the type plate (where applicable).

• **Replacing lamp:**

- Disconnect the luminaire.
- Allow sufficient time to cool down, see type plate.
- Undo locking screw (3); this releases the safety tab (4) for the screw-type glass lens (6).
- Unscrew glass lens (6) using only the special claw spanner.
- Pull out the defective light bulb (2-pin type).
- Hold the new lamp (original products only, please) using a protective cloth, taking care not to touch it with your bare fingers. Carefully insert the replacement 2-pin bulb into its socket, making sure the lamp is securely in place!
- Refit the glass lens (6) by screwing it into place until it is tight again (pressure on O-ring).
- The safety tab (4) has to engage in the notch provided to ensure that the glass lens (6) is locked in position.
- Retighten the locking screw (3).
- Switch on power again.

• **Warning:**

Do not look into light – Danger of impaired eyesight!
When replacing light bulbs, make sure that the light beam is evenly distributed over the glass lens. On no account should a "hot spot" be allowed to occur outside the luminaire (caused e. g. by the incorrect position of the lamp or the wrong type of light bulb).

• **Please note:**

Please order mounting parts and claw spanner separately if needed.

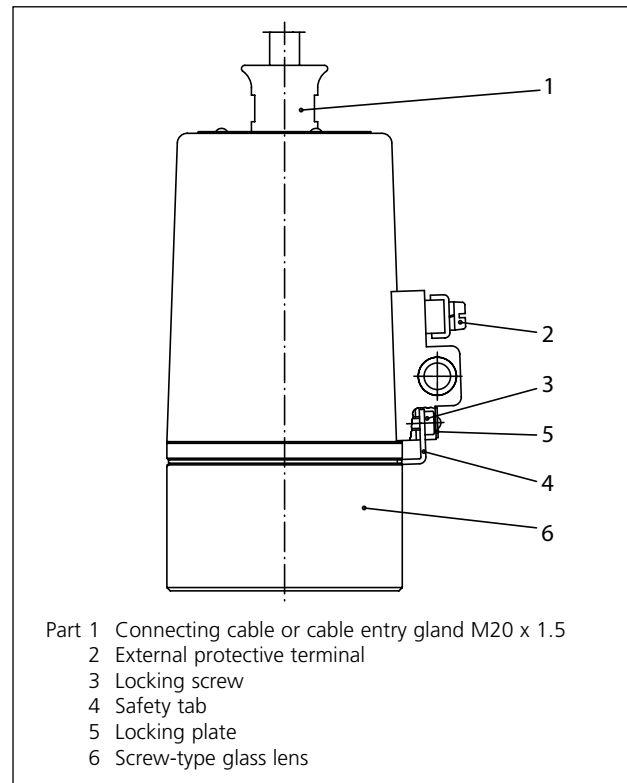

• **Replacement parts:**

	Part no.
Screw-type lens (light aperture with reflector)	1774.051.00
Screw-type lens (light aperture without refl.)	1774.050.00
O-ring seal (Viton)	0862.073.00

Lamp socket GU4 (2-pin)	1202.023.00
Lamp socket G4 (2-pin)	1202.011.00

Flared cable entry gland (Ex d M20 x 1.5)	9103.105.00
---	-------------

(Halogen) lamps:

12 V/5 W	3232.221.00
12 V/10 W	3232.224.00
12 V/20 W	3232.229.00
24 V/20 W Halogen reflector lamp	3232.222.00
24 V/20 W from construction year 07.2017	3232.206.00
Cold light 12 V/20 W	3232.258.00

Cable entry gland...

complete with 2 m connecting cable	1084.021.00
complete with 10 m connecting cable	1084.024.00

• **Accessories:** Claw spanner

6816.001.00

• **Servicing:**

- Keep luminaire clean.
- Before closing the luminaire again, re-grease the threads in the glass lens (6) using e. g. AEMA-SOL 6B from A. E. Matthes.
- Keep a note of average lamp life.
- Use only original replacement parts.