

## Lumiglas Mini-Luminaire Stainless Steel, Model USL01

Data sheet 06.11

- **For use with sightglass fittings**

This Lumiglas mini-luminaire is available in two versions:  
 1) with integral mounting clamp enabling it to be fitted onto a Lumiglas-sightglass wiper assembly, type SW I (standard)  
 2) with hinged mounting bracket

This miniaturised luminaire is suitable for use with **combined (single port) light/sightglasses** as well as **separate (two port) arrangement**.

- **Extremely compact, high light output:**

Dazzle free lighting; fits circular sight glass units to DIN 28120 / 28121 or similar and likewise rectangular units and screwed sightglass fittings to DIN 11851.

- **External diameter:** 24 mm

- **Application:**

Primarily intended for the pharmaceutical and food processing industries; ideal for lighting internals of small vessels such as bio-reactors, laboratory mixers, filters, separators, stirred pressure vessels, miniature tanks, pipelines and other normally enclosed systems in **Non Ex hazardous areas**.

- **Protection:**

Dust and water spray tight IP 65 to EN 60 529/DIN VDE 0470 Part 1

- **Operating conditions:**

Independent of vessel internal pressure or vacuum;  
 max. permissible ambient temperature 90° C

**On no account may the luminaire be used as a closure/means of sealing of a (pressure) vessel i.e. without a suitable sightglass fitting.**

- **Electrical data:**

The unit is factory fitted with 3 m of connecting cable.

- **Power supply:**

without integral push button

12 V halogen filament lamp 5 W, 2 pin socket G 4

with integral push button

12 V halogen filament lamp 20 W, 2 pin socket G 4

- **Transformers:**

Transformers for 12 V or 24 V secondary winding can be supplied on request.

- **Integral push button:**

The 20 W units are only supplied with integral push button switch.

- **Mounting brackets:**

The clip on mounting clamp for the Lumiglas-wiper assembly (type SW I) is included in the supply as standard.  
 If the option of hinged bracket is required, it should be ordered separately.



Lumiglas Mini-Luminaire Stainless Steel, Model USL01 with mounting clamp fitted on a screwed sightglass fitting with Lumiglas sightglass wiper type SW I



Lumiglas Mini-Luminaire Stainless Steel, Model USL01 with hinged bracket.

• **Dimensions of the Lumiglas Mini-Luminaire Stainless Steel, Model USL01:**

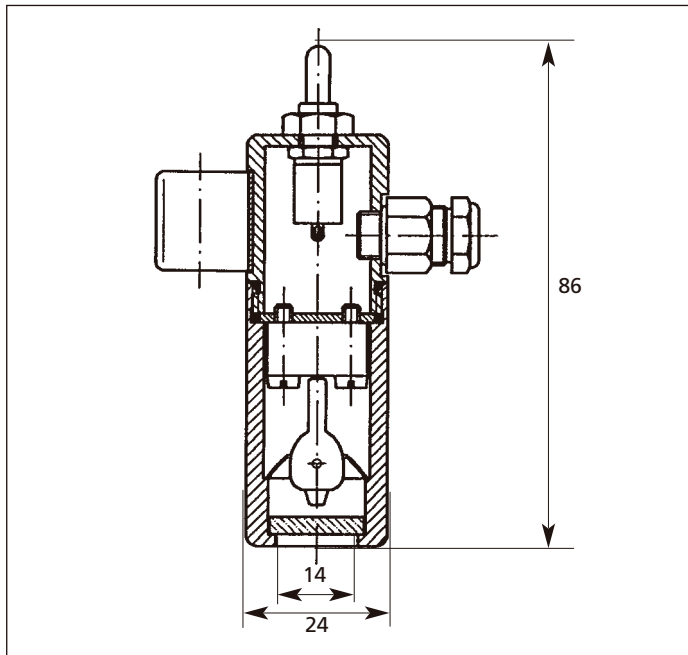

• **Replacement parts: halogen filament lamp**

Power	Socket	Cat. No. <sup>1)</sup>
12 V/5 W	G 4	3232.221.00
24 V/20 W	G 4	3232.206.00

• **Example of fastening:**



Lighting port assembly, showing Lumiglas Mini Luminaire Stainless Steel, Model USL01, with hinged bracket fitted to screwed sightglass (MV 50)

• **Material and parts:**

- body and head: stainless steel 1.4404
- mounting bracket: stainless steel (both for hinged version and SW1 wiper clamp)
- connecting cable: 3 m (3 x 0.5 mm<sup>2</sup>)
- weight: appx. 0.150 kg

• **Ordering specifications (example):**

- Lumiglas Mini Luminaire Model Stainless Steel, Model USL01, 24 V/20 W with push button, cat. no. 3540.002.00, mounting clamp version

• **Power connecting data and fastening:**

Lumiglas Mini-Luminaire Stainless Steel USL01			
Item	Model USL01	Cat. No. <sup>1)</sup>	Supply V
<b>mounting clamp</b>			
1	(12 V) 5 W without p. button	3540.001.00	12
2	(24 V) 20 W with p. button	3540.002.00	24
<b>hinged bracket</b>			
3	(12 V) 5 W without p. button	3540.003.00	12
4	(24 V) 20 W with p. button	3540.004.00	24
<b>outer adapter flange</b>			
5	(12 V) 5 W without p. button	3540.005.00	12
6	(24 V) 20 W with p. button	3540.006.00	24

<sup>1)</sup> = ordering no.