

## Lumiglas aseptic screwed sight glass fitting MV-S

similar to DIN 11864.1 (dairy type screwed fittings)

Aseptic pipeline screwed fittings with fused metal sight glass discs for visual process observation. The screwed nozzles have weld necks.

### • Application:

For observing the internals of process vessels such as bioreactors, laboratory mixers, filters as well as tanks, stirred vessels, separators, pipelines and other normally closed systems. Particularly suited to aseptic operating conditions as well as pharmaceutical and food industries.

### • Operating conditions:

Pressure: up to approx. 25 bar, depends on size, vacuum

### • Temperatures:

approx. 300°C at fitting; dependant on material of metal surround of fused metal glass sight glass disc (METAGLAS®).

### • Component materials shown in adjoining view are

item	part	material
1	slotted cover nut	stainless steel 1.4301 (1.4307) or 1.4404
2+3	slotted cover nut sight glass disc METAGLAS®	metal surround alternatively: 1.4462 up to 280°C 2.4602, 2.4605, 2.4610 up to 300°C, borosilicate glass, approx. 25 bar either:
4	gasket	EPDM; HNBR; FKM; MVQ
5	welding nozzle	stainless steel 1.4404 or 1.4435

### • Mounting:

After welding the nozzle (5) into the vessel wall, gasket (4) and fused sight glass disc (2) and (3) are laid into the nozzle seating in the order shown and the cover nut (1) tightened down.

### • Caution:

Check and ensure that the fused metal sight glass disc (2 + 3) and the O-ring gasket (4) lie correctly in the nozzle fitting (5)!



Complete scope of supply of the Lumiglas aseptic  
screwed sight glass fitting MV-S

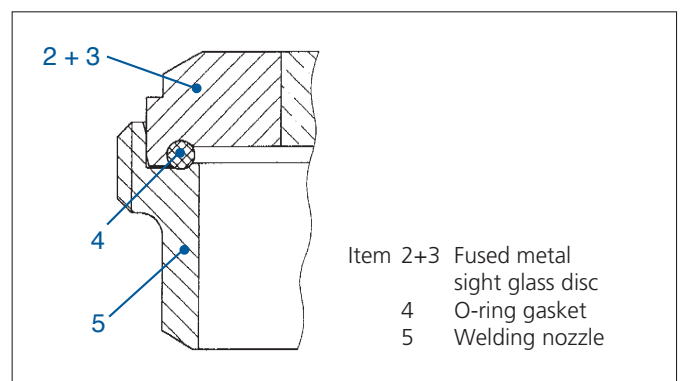
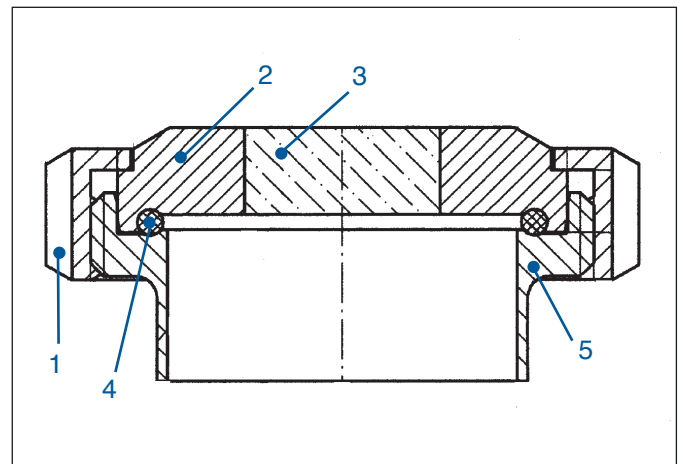

Assembly of Lumiglas aseptic screwed sight glass fitting MV-S

• Dimensions and electrical data of Lumiglas aseptic screwed sight glass fitting MV-S

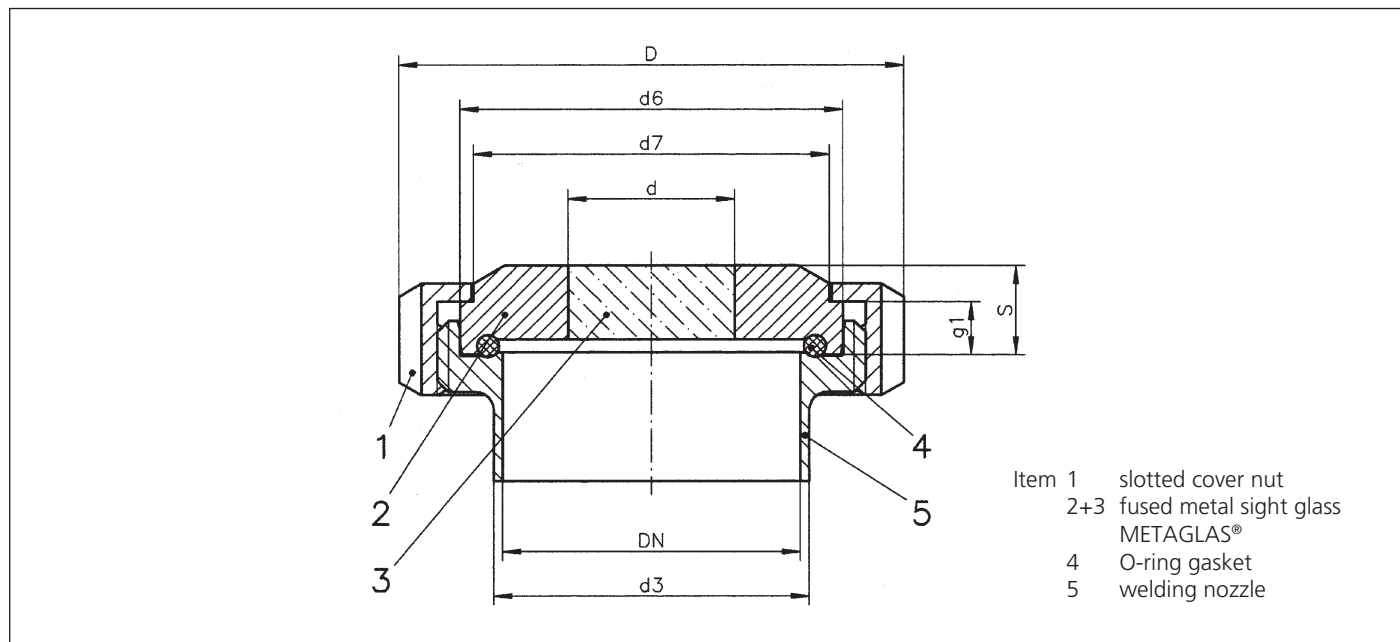

Size		1	2	3	4	5
Nominal bore	DN	40	50	65	80	100
Fitting	D	78	92	112	127	148
Fitting	d3	41	53	70	85	104
O-ring		40 x 5	52 x 5	68 x 5	83 x 5	102 x 5
Viewing dia.	d	28	34	37	47	55
Outside-Ø under side	d6	54.9	66.9	84.9	98.9	118.9
Outside-Ø approx. upper side	d7	48	61	79	93	114
Thickness, total	s	14	15	20	20	25
Thickness	g1	10	11	12	12	15
Pressure approx.	bar	25	25	16	16	10

• Possible combination:

Combination with various sterile technology Lumiglas luminaires is possible, both in Ex and non Ex-environment.

• Order data:

- Aseptic screwed sight glass fitting similar to DIN 11864.1
- Nominal bore: DN 80 PN, max. 16 bar, 300°C
- Please indicate desired material of construction
- Should the fused metal sight glass be supplied with an adapter for mounting on a sterile technology Lumiglas luminaire?

All dimensions in mm unless stated otherwise. Subject to change without prior notice.