

Lumiglas sight glass wiper with flexible drive SW II BW

for use with circular sight glass assemblies to DIN 28120 or similar

• Mounting:

By means of pressure tight glands through both base and cover flange of sight glass assembly; suitable for sight glass discs corresponding to DIN 7080 or DIN 8902.

• Application:

For manually activated cleaning, when required, of inside face of glass in sight ports. Particularly suitable for pressure and vacuum, vessels requiring test certification both **in explosion hazardous as well as non hazardous** operating areas. The glass discs fitted into the assemblies correspond to DIN 7080 or DIN 8902 standards. Suitable for circular sight glass assemblies nominal size DN 100 ... DN 200.

• Operating conditions:

Vacuum tight; pressure tight to 16 bar.
Max. permissible temperature: 220°C (depending, however, on type of glass disc used).

• Possible combinations:

Simultaneous fittings of Lumiglas luminaire, flame proof or standard design, is possible with the wiper SW II BW, as is the fitting of a spray device.

• Certification/Testing:

Test certificates issued by the state material testing authority Nordrhein Westfalen, Dortmund, are available.

• Assembly/materials alternatives for the complete supply:

Wiper blade: PTFE or silicone rubber
All product contact parts are of stainless steel.
Mechanical drive internal seal: PTFE



Lumiglas SW II BW mounted into sight glass fitting DIN 28120

• Assembly and installation instructions:

The wiper is actuated by flexible shaft which engages at one end in the wiper blade holder and at the other in a lever operated ratchet drive mechanism which ensures drive shaft is always rotated in same direction.

A separate set of detailed installation instructions is included in the supply.

Should you order a complete sight glass assembly with the wiper SW II BW, the additional machining of the base will be carried out by Papenmeier.

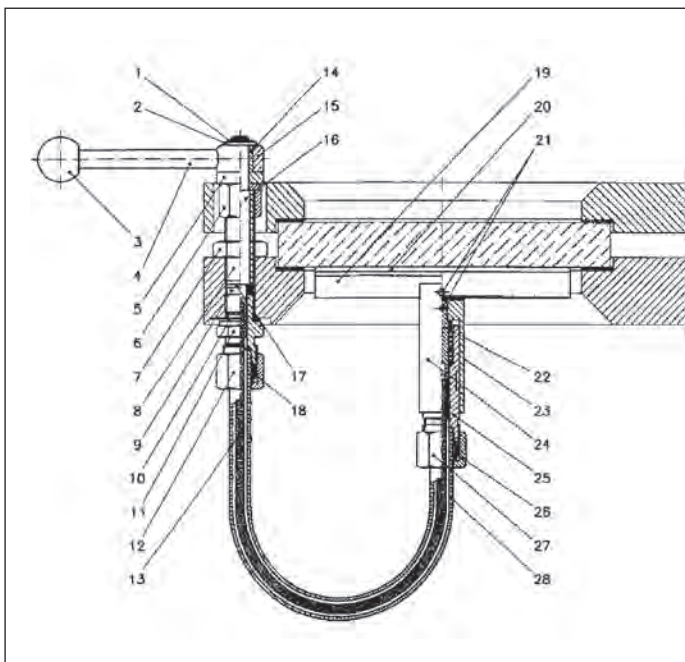

Item	Part	Item	Part
1	Locking circlip 1.4568	15	Drive boss 1.4305
2	Washer A2	16	Shaft drive shank 1.4305
3	Actuating knob (brass insert)	17	Washer galvanized steel
4	Ratchet drive lever arm 1.4305	18	Compression taper ring 1.4571
5	Spacer ring 1.4305	19	Wiper blade holder 1.4571
6	Cap nut Zn8c	20	Wiper blade silicone or PTFE
7	Locknut A4	21	Roll pin 1.4571
8	Threaded bush 1.4301	22	Wiper arm axle 1.4571 or 1.4401
9	Packing ring PTFE	23	Coil spring 1.4310
10	Gasket PTFE	24	Wiper carrier shroud 1.4571 or 1.4401
11	Tube securing bush 1.4571	25	Guide spigot 1.4571 or 1.4401
12	Compression nut 1.4571	26	Compression taper ring 1.4571
13	Flexible drive shaft 1.4310 or 1.4401	27	Compression nut 1.4571
14	Ratchet drive unit steel	28	Guide tube 1.4571

• Dimensions for Lumiglas sight glass wiper SW II BW

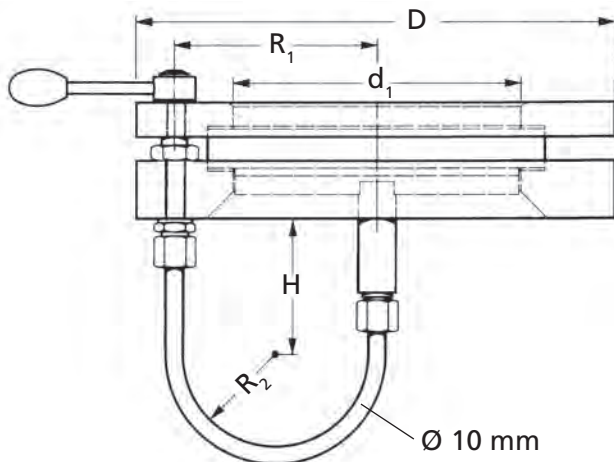

size		1	2	3	4
nominal bore assembly	DN	100	125	150	200
viewing diameter	d1	125	150	175	225
flange	D	220	250	285	340
wiper	R 1	93	105	120	147.5
	R 2	41.5	47.5	55	68.75
	H	80.5	70.5	86	64.5
part no.		7223.034.00	7223.035.00	7223.036.00	7223.037.00

• Spare parts

wiper blades	for size/DN	wiper blade length (mm)	silicone part no.	PTFE part no.	
	1/100	115	9468.020.00	9468.031.00	
	2/125	140	9468.021.00	9468.032.00	
	3/150	165	9468.022.00	9468.033.00	
	4/200	215	9468.023.00	9468.034.00	
flexible drive	for size/DN	part no.			
	1/100	9323.014.00			
	2/125	9323.014.00			
	3/150	9323.016.00			
	4/200	9323.016.00			

• Order data:

e. g. Lumiglas sight glass wiper SW II BW, size 3, wiper blade silicone rubber.

If ordering with complete sightport assembly please give the following additional information:

1. Sight glass assembly (DN/PN), materials.
2. Type and size of sight glass disc (borosilicate/sodalime).

All dimensions in mm unless stated otherwise. Subject to change without prior notice.