

Screwed Sight Glass Fitting MV

Screwed sight glass fittings similar to DIN 11851 (dairy standard fittings) with see-through circular glasses. Threaded nozzles have weld necks.

• Application:

Weld-on sight glass fitting with screwed cover flange. Sightport for viewing into Bioreactors, Laboratory mixers, filters as well as into process vessels, separators, pipelines and other usually closed containers.

Particularly suitable for pharmaceuticals, food and beverage processing, e. g. breweries, dairies etc.

• Operating Conditions:

Pressure: 6 bar (higher pressure ratings on request), vacuum

• **Temperatures:** Fittig: max. 280°C, with flat sealing face and flat gasket and with requisite profile seal (4) – see temperature diagram.

• Combinations:

This sight glass unit can be combined with several Lumiglas luminaires. Lumiglas wiper type SW I can be fitted to sizes DN 50 and larger. Combination of luminaire plus wiper can be fitted to size DN 125.

• **Parts and materials**, shown in adjoining exploded view, are

Items	Parts	Material options
1	slotted cover nut	stainless steel 1.4301 (1.4307)
2	flat gasket	KLINGERSil C-4400
3	sight glass disc	- soda lime glass: toughened (tempered) to DIN 8902, for max. temp. 150°C - borosilicate glass: toughened (tempered) to DIN 7080, for max. temp. 280°C
4	O-ring seal (max. 250°C)	Viton, PTFE, Buna, Silicone, EPDM
5	weld neck nozzle	stainless steel 1.4301 (1.4307); 1.4404
6	vessel wall	

• **Temperature diagramm serves for choice of material option**

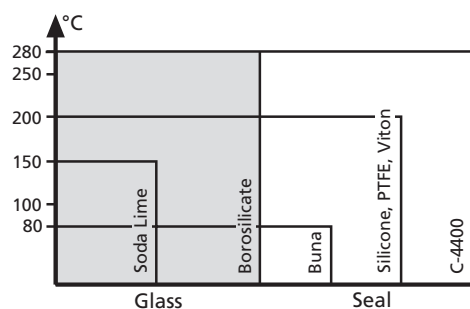

• Assembly:

After welding nozzle (5) into the vessel wall (6), O-ring seal (4), glass discs (3) and flat gasket (2) are assembled in the sequence shown and tightened down by the slotted cover nut (1) against nozzle (6).



Complete screwed sight glass fitting MV

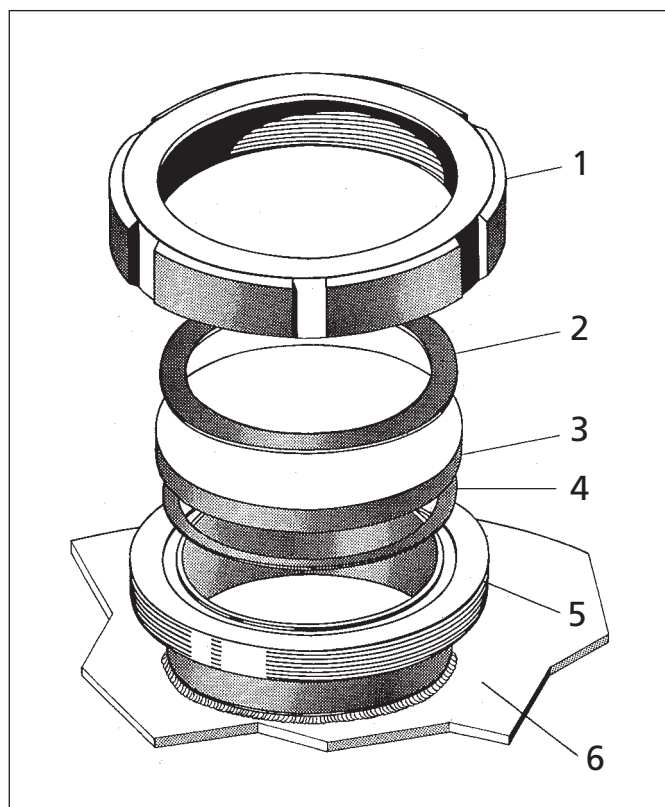

Exploded view of an MV screwed sightglass fitting

• **Dimensions of Screwed Sight Glass Fitting MV:**

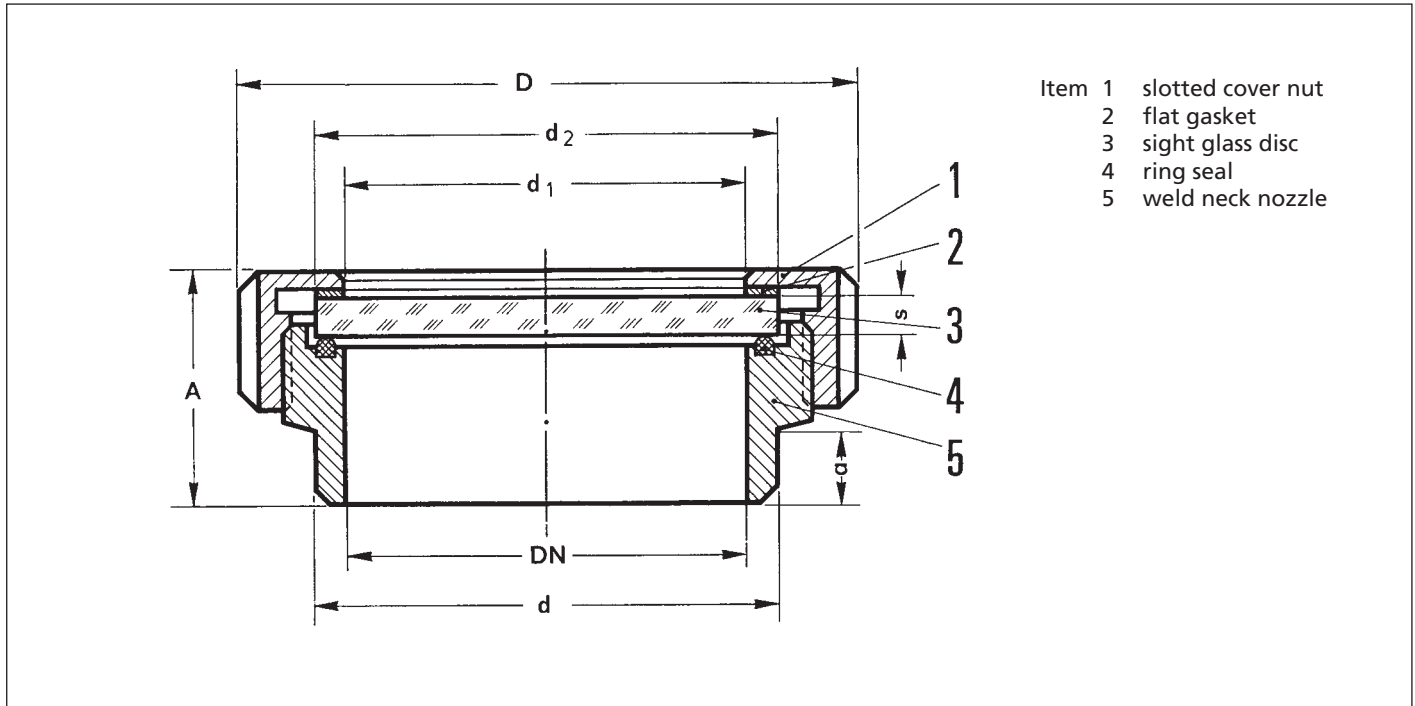

Size		1	2	3	4	5	6
Nominal bore	DN	50	65	80	100	125	150
Viewing diameter	d ₁	50	65	80	100	125	150
Sight glass disc	d ₂	63	80	94	113	141	166
	s	10	12	12	15	15	15
Fitting	D	92	112	127	148	178	210
	d	61	79	93	114	136	163
	A	44	52	57	69	59	62
	a	21	24	25	34	22	22

• **Ordering Information:** e. g.

- screwed sight glass fitting to DIN 11851
- nominal size: DN 80 PN 6 bar
- materials to be specified for:
 - slotted cover nut (restricted to 1.4301)
 - weld neck nozzle
 - sight glass discs
 - seals

All dimensions in mm unless stated otherwise. Subject to change without prior notice.
ric 01.11 3755.168 a