

## Circular sight glass fitting DIN 28120 or similar

Sight glass fittings acc. to DIN 28120 are circular flanged ports for welding into and onto the vessel wall. The block and the cover flange are screwed together tightly, with the sight glass disk and an independent gasket to the upper and the lower flange respectively positioned between them.

The structure and dimensions comply with the design standards set out in DIN 28120 for sizes DN 50 to DN 200. Flange thicknesses dimensioned according to this standard ensure the distortion-free positioning of the sight glass disk, provided the block flange is properly welded onto or into the wall of the vessel.

### • Application:

For viewing of internals of pressure vessels, tanks, silos, stirred vessels, separators pipelines etc.

### • Operating conditions:

Pressure: 10 bar or 16 bar, depends on size,  
higher pressure rating on request;  
vacuum

Temperature: max. 150°C with sodalime glass DIN 8902  
max. 200°C with borosilicate glass DIN 7080  
higher temperatures on request

### • Possible combinations:

Can be combined with Lumiglas luminaires when used in explosion hazardous as well as non explosion hazardous areas. The cover flange is then drilled and tapped to suit luminaire mounting bracket.

### • Certificates/testing:

Depending on customer requirements and at extra cost, can be provided to DIN EN 10204 3.1/3.2

### • Component materials shown in adjoining exploded view are

item	part	material
1	base flange (welding flange)	carbon steel RSt 37-2, stainless steel or other
2.1, 2.2	fastening bolts	carbon steel 5.6/5 or stainless steel A2
3.1, 3.2	gaskets	KLINGERSil C-4400; silicone, PTFE or other
4	sight glass disc	- sodalime glass: toughened DIN 8902 - borosilicate glass: toughened DIN 7080
5	cover flange	carbon steel RSt 37-2; stainless steel 1.4541 or other
6	vessel wall	

### • The following temperature diagram simplifies material selection:

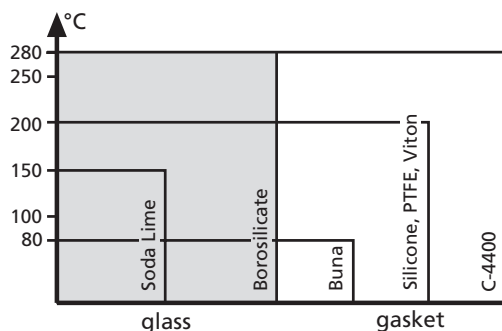

Circular sight glass fitting DIN 28120

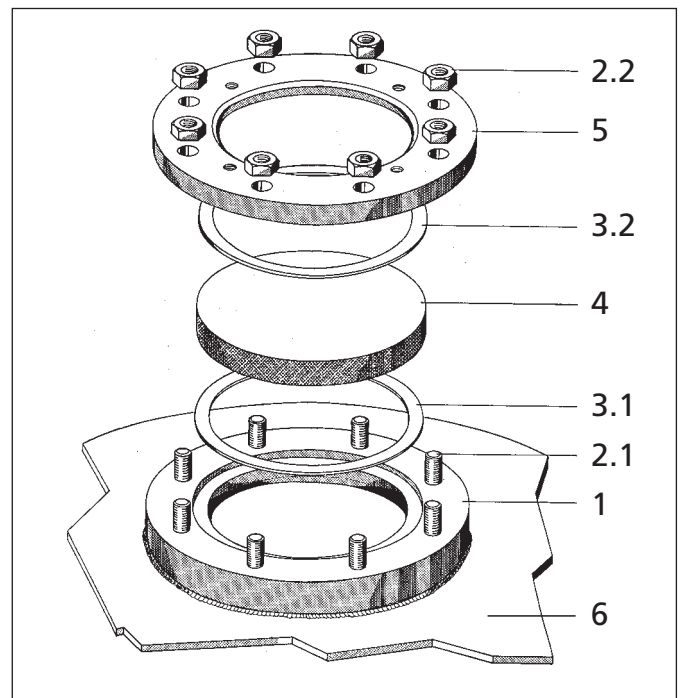

Exploded view of circular sight glass fitting DIN 28120

### • Installation:

After welding base flange (1) onto or into vessel wall, seals (3.1 & 3.2), glass disc (4) and cover flange (5) are placed together in the order shown. Then the nuts (2.2) in case of studted base flange and washers are progressively tightened, always working on diametrically opposed pairs of nuts at a time. Tightening torque values are given in table on overleaf. For more information see DIN 28120.

• Dimensions for circular sight glass fitting DIN 28120/PN 10/16 or similar DIN 28120/PN 6

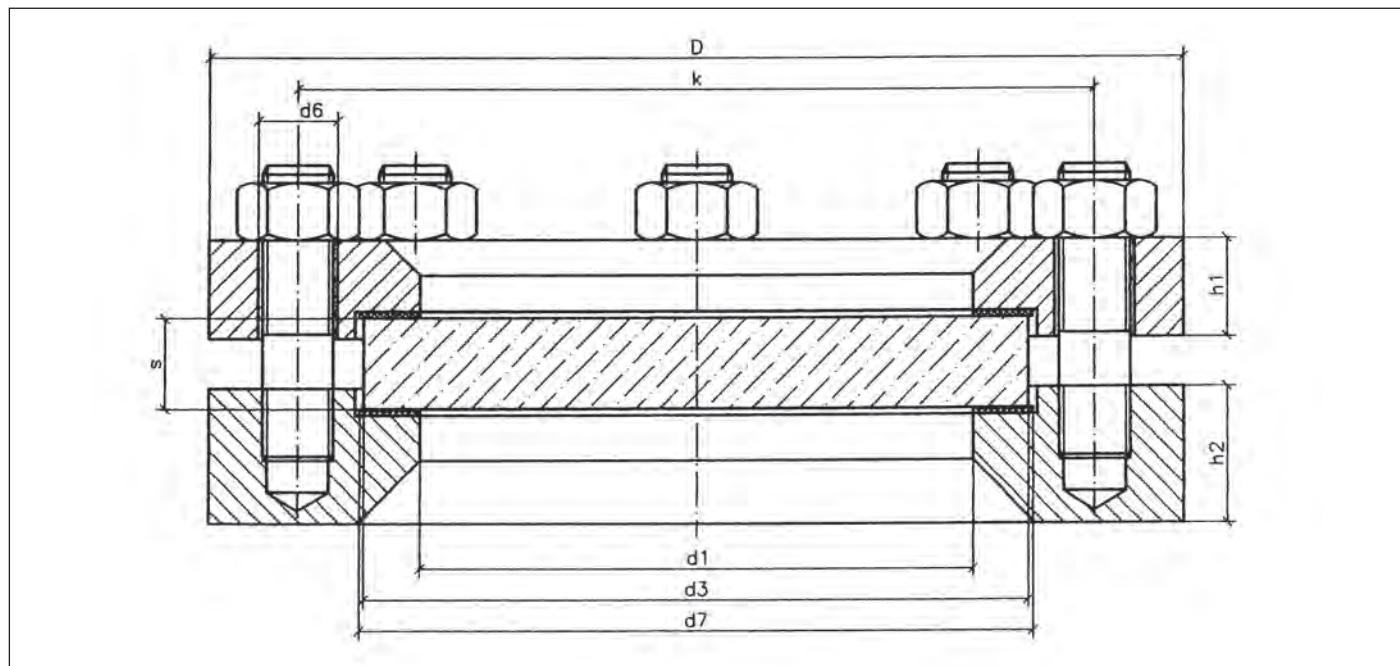

size		1	2	3	4	5	6
normal bore	DN	50	80	100	125	150	200
pressure rating (bar)	PN	10/16	10/16	(6) 10/16	(6) 10/16	(6) 10/16	(6) 10
viewing diameter	d1	80	100	125	150	175	225
sight glass disc	d3	100	125	150	175	200	250
	s	15/15	15/20	(20) 20/25	(20) 20/25	(20) 25/30	(25) 30
flanges	D	165	200	220	250	285	340
	k	125	160	180	210	240	295
	d6	18	18	18	18	22	22
	h1	16/16	20/20	(18) 22/22	(18) 25/25	(18) 30/30	(20) 35
	h2	30	30	30	30	36	36
fastening bolts	no.	4	8	8	8	8	8
	size	M 16	M 16	M 16	M 16	M 20	M 20
gaskets (side with product contact and atmospheric side)	d1	80	100	125	150	175	225
	d7	102	127	152	177	202	252
tightening torque for bolts lubricant factor/μ 0.1	Nm	28/32	20/23	26/30	32/34	47/54	63

• Order data:

- fitting (DIN)
- nominal bore (DN) / nominal pressure (PN)
- material: base flange, test certification 3.1/3.2 on request  
cover flange, test certification 3.1/3.2 on request  
bolts  
glass disc  
gaskets

• Pressure rating conversion:

- 6 bar = 87 psi
- 10 bar = 145 psi
- 16 bar = 232 psi

All dimensions in mm unless stated otherwise. Subject to change without prior notice.