

Lumiglas Light/Screwed Sight Glass Unit with Luminaires Type MV-SLM and MV-ME

Screw-type sight glass fittings similar to DIN 11 851 (milk-proof screw closures) with special version of Lumiglas luminaire installed. Units available in **stainless steel** or aluminium allowing the combination of sight glass and light port, sizes DN 65 to DN 125.

- **Application:** For illuminating bio-reactors, laboratory mixing vessels and filters, as well as the interiors of tanks, agitators, silos, separators, pipelines, and other – usually closed – vessels in potentially non-explosive operating environments, especially in the pharmaceutical, food and beverage processing industries, e. g. breweries and dairies.
- **Protection:** When correctly fitted, dust and waterjet proof to IP 65, EN 60 529/DIN VDE 0470 Part 1.
- **Operating Conditions:** Pressure: max. 6 bar (higher pressure ratings on request), vacuum
- **Temperature:** Fitting: max. 220°C
Temperature at the cable gland: 80°C.
Where ambient temperature lies above 40°C heat resistant cable, e. g. Sinotherm 110 H05GG-F 3G 1,5 mm² must be fitted. Lumistar luminaire type ME is equipped with 3 m cable (factory-made), temperature resistant up to 90°C.
- **Electrical Data:**
 - Power supply 24 V (12 V available as alternative)
 - Lamp 2-pin halogen lamp 20 W, 50 W, 100 W
- **Lamp holder:** 2-pin socket
- **Pushbutton:** The luminaires are supplied with built-in pushbutton
- **Transformers:** Can be supplied optionally.
- **Parts and alternatively materials,** drawing on the right:

Item	Part name	Material options
1	Lumiglas luminaire	
1.1	luminaire housing	alternatively: cast alum. painted (RAL 9007) or stainless steel 1.4301, polished
1.2	luminaire cover	
1.3	flat seal with bridge	Silicon (max. 220°C)
2	screwed sight glass fitting	
2.1	slotted cover nut	stainless steel 1.4301 (1.4307)
2.3	sight glass disc	soda lime glass toughened (tempered) to DIN 8902, max. temperature: 150°C borosilicate glass: toughened (tempered) to DIN 7080, max. temperature: 280°C
2.4	ring seal (alternatively)	Viton, PTFE, Perbunan, Silicon
2.5	weld neck nozzle	alternatively: stainless steel 1.4301; (1.4307); 1.4404
3	vessel wall	

CE

Data sheet 08.01

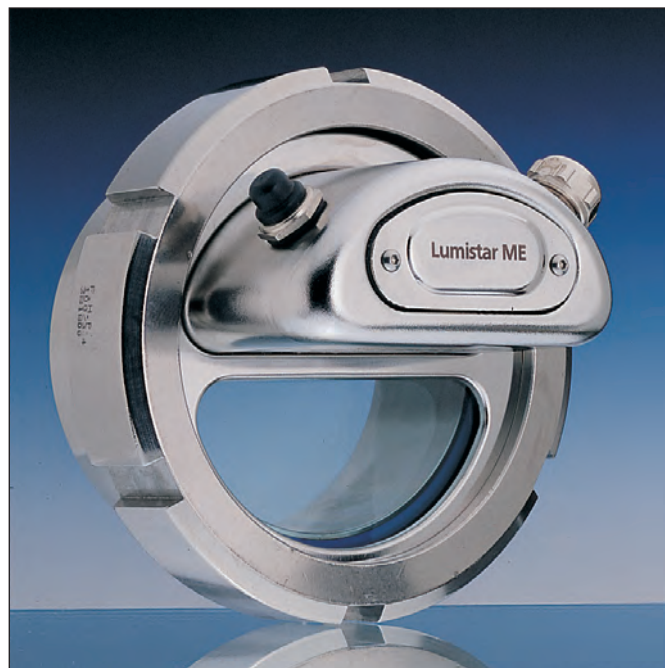

Complete unit of a Lumiglas light/screwed sight glass unit with luminaires type Lumistar ME

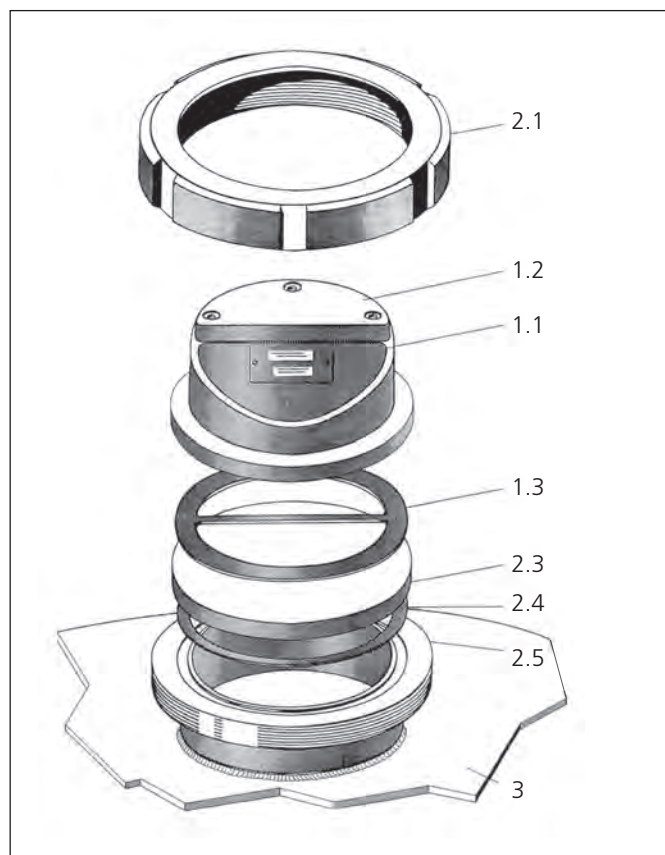

Light/screwed sight glass unit with luminaires type MV-SLM

• **Dimensions and electrical data of Lumiglas light/screwed sight glass unit with luminaires type MV-SLM and MV-ME**

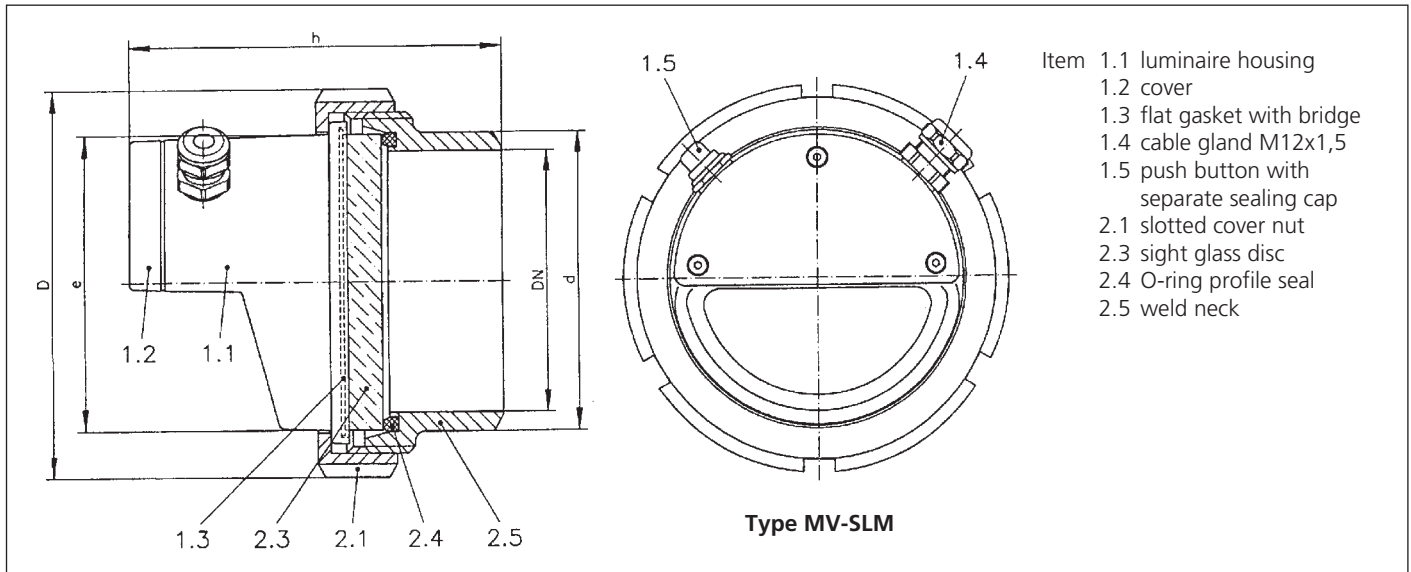

• **Parts, Construction and Materials:**

- Luminaire body: Corrosion resistant die cast aluminium, painted RAL 9007 (suitable for food processing) or stainless steel 1.4301.
- Luminaire cover (1.2) is screwed to luminaire housing (1.1) with inserted flat flexible gasket to form the connector box.

A built-in push button with separate sealing cap (1.5) for intermittent use is standard.

- Lumiglas luminaire ME is inclusive 3 m cable tail to 90°C.

Size		1	2	3	4*	
Lumiglas luminaire	Type	MV 65/SLM 65	MV 80/SLM 80	MV 100/SLM 100	MV 125/SLM 125	luminaire aluminium
compatible	DN	65	80	100	125	* can be combined with Lumiglas sight glass wiper type SW I The dimension h of version MV/ME (stainless steel) is lowly different.
voltage	V	24	24	24	24	
wattage	W	20	20	50	50, (100 only SLM)	
dimensions	D	112	127	148	178	
	d	79	93	114	136	
	e	78	92	113	136	
	h	110	125	143	140	
alternatively	Type	MV 65/ME 65	MV 80/ME 80	MV 100/ME 100	MV 125/ME 125	luminaire stainl. steel

• **Mechanical Installation of Assembly:**

Please note: Electrical connection should be carried out only after the mechanical fitting! Lumiglas luminaire and flat seal (1.3) are bonded together at the factory and come as a unit. After welding nozzle (2.5) into the vessel wall (3), fit O-ring seal (2.4), glass disc (2.3) and luminaire (1.1) as shown in the drawing overleaf. Tighten all these parts down against the nozzle by cover nut (2.1). Always use the special 'C-Spanner'. Finally check if the sight glass disc sits correctly in the fitting. Please refer also to Data sheet 01.06 (Screwed sight glass fittings series MV).

• **Ordering Information:** Please state for example: Lumiglas light/screwed sight glass unit MV 80/ME 80, 24 V – 20 W

- **Details:** please refer to separate data sheets or installation and operating instructions:
 - 06.02.01 Lumiglas luminaires, Lumistar SLM (Alu)
 - 06.02.02 Stainless steel Lumiglas luminaires, Lumistar ME
 - 01.06 Screwed sight glass fittings series MV