

Lumistar Luminaire ESL 53-LED, Stainless Steel

ESL 53-LED-KS: for general use with hinged bracket

ESL 53-LED-B: special sterile version for flange attachment for fitting over flanges, collars, etc.

- **For mounting on sight glass fittings:**
This sight glass luminaire is designed for universal applications and is ideal either in combined sight and light ports (single-flange version) or with separate ports (two-flange version).
 - **Compact design, powerful light output:**
Glare-free illumination; fits circular sight glass fittings to DIN 28120/DIN 28121 or similar, screw-type sight glass fittings in compliance with DIN 11851, as well as METAGLAS® and BioControl fittings.
 - **Applications in the chemicals, pharmaceutical, biogas and food processing industries:**
For illuminating the interior of vessels, tanks, agitators, silos and other generally closed containers and reactors and also in visual flow indicators in non-explosive environments.
 - **Protection class:** dust-tight and water jet-proof, IP 65 acc. to EN 60 529 / DIN VDE 0470 part 1
 - **Operating conditions:**
Independent of vacuum/pressure in the vessel. Under no circumstances should a sight glass luminaire be used as a substitute for the cover flange or instead of the complete sight glass flange assembly, or on its own to close a vessel port.
 - **Maximum admissible ambient temperature:** 40°C
 - **Straightforward installation using a special attachment, ensuring convenience of use:**
The luminaire is fixed to the cover flange by a hinged bracket in the case of circular sight glass fittings and visual flow indicators. With screw-type sight glass fittings, the luminaire can be fastened with a flange adapter or with a Metaglas unit.
- Lumistar luminaires ESL 53-LED fit the following nominal sizes:**
- a) Circular sight glass fitting acc. to DIN 28120: from DN 25
 - b) Circular sight glass fitting acc. to DIN 28121: from DN 40
 - c) Visual flow indicator: from DN 25
 - d) Screw-type sight glass fitting in compliance with DIN 11851: from DN 50
- **Mounting elements:**
 - for ESL 53-LED-KS: The hinged bracket is included in the scope of supply
 - for ESL 53-LED-B: The flanged adapter for mounting on a screw-type sight glass fitting needs to be ordered separately
 - **Caution:** Never look into the light source – risk of damage to the eyes!
 - **Voltage type:** AC/DC
Operating voltage: 24 V AC/DC
Output: 7 W
 - **Transformers** for 230 V AC / 24 V AC are available on request

CE

3755.322



Lumistar luminaire ESL 53-LED-KS with hinged bracket

- **Operation:**
This luminaire is designed for continuous operations. As an alternative, however, it can also be supplied with a switch or pushbutton (see chart).

• Dimensions and electrical data for Lumistar luminaires ESL 53-LED:

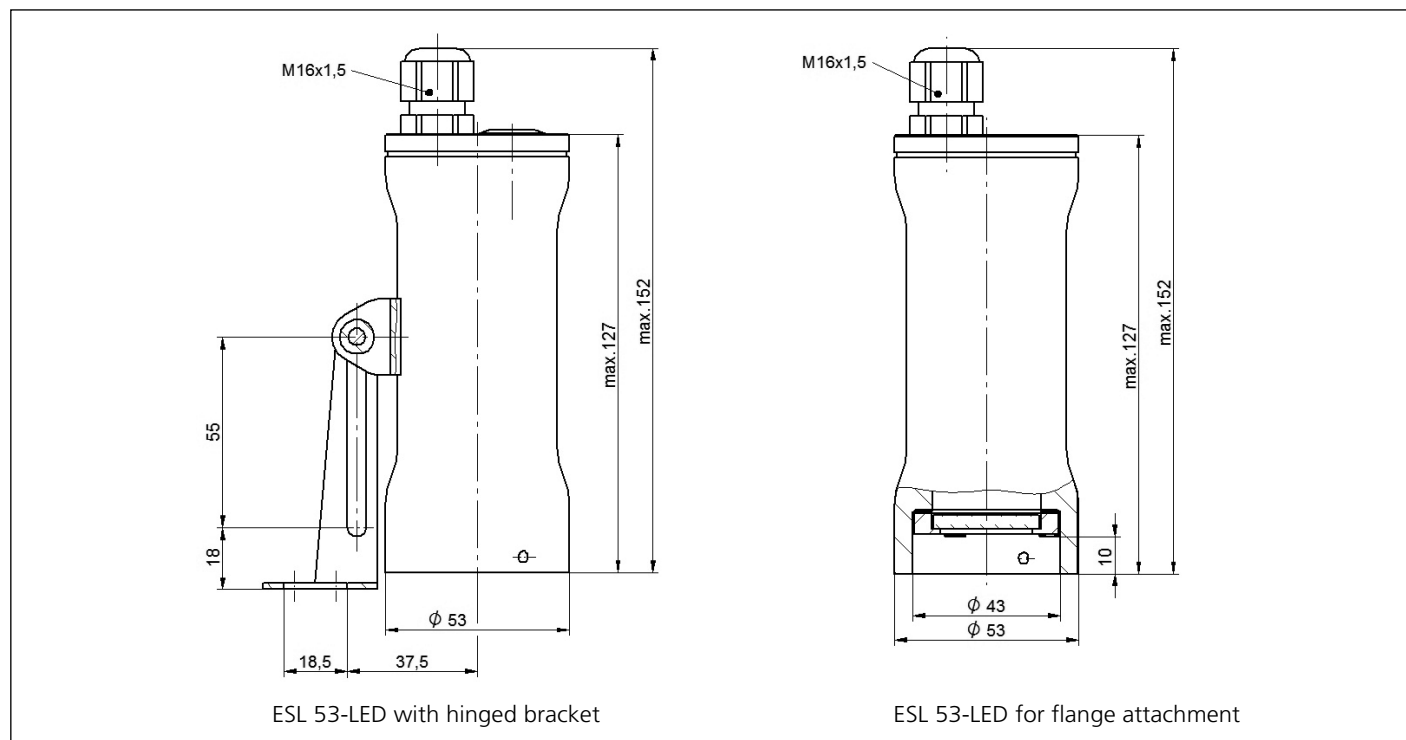

ESL 53-LED with hinged bracket

ESL 53-LED for flange attachment

• Description and materials:

- Luminaire body: stainless steel 1.4404
- Hinged bracket and flange adapter for fastening the luminaire to screw-type sight glass fitting DN 50/65: stainless steel 1.4301
- Connecting cable: 3 m (3 x 0.75 mm²) factory-fitted (other lengths on request)
- Weight: 1.1 kg including hinged bracket and cable

• Connecting data:

No.	Type	Push button	Switch	Hinged bracket	Flange attachment	Part no.
1	ESL 53-LED-KS	with	without	with	without	3541.901.00
2	ESL 53-LED-KS	without	without	with	without	3541.902.00
3	ESL 53-LED-B	with	without	without	with	3541.903.00
4	ESL 53-LED-B	without	without	without	with	3541.904.00
5	ESL 53-LED-KS	without	with	with	without	3541.905.00
6	ESL 53-LED-B	without	with	without	with	3541.906.00

• Accessories (for ESL 53-LED-B only)

Item	Luminaire mounting element	Part no.
1	Flange adapter DN 50, stainless steel (hinged bracket not required / DIN slotted nut)	1356.027.00
2	Flange adapter DN 65, stainless steel (hinged bracket not required / slotted nut with 65 mm viewing aperture)	1356.030.00
3	Flange adapter DN 80, stainless steel (hinged bracket not required / DIN slotted nut)	1356.031.00

- **Order data:** e. g. Lumistar luminaire ESL 53-LED-KS, with pushbutton, part no. 3541.901.00