

Installation and Operating Instructions **CE**

0093.132.00

Lumistar Luminaire USL 05-LED

• Important, please note:

Sight glass luminaires are purpose-designed and intended solely for mounting on or near sight glass flange fittings. Under no circumstances should a sight glass luminaire be utilised as a substitute for the mating flange or the complete sight glass flange fitting or used on its own to cover a vessel port. Lumistar luminaires must always be installed, connected and serviced by persons who have been specially trained and authorised to do this work.

• General operating conditions:

- Independent of internal pressure/vacuum in the vessel
- Max. admissible ambient temperature: 50°C

• Elektrische Daten allgemein:

- Voltage, output and protection class are specified on the type plate
- Excess voltage will cause the luminaire to fail prematurely

• Mechanical installation:

In the case of the circular sight glass fitting and flow sight glasses, the luminaire is attached to the mating flange by a hinged bracket. For screwed sight glass fittings, the luminaire is mounted on the slotted nut or, alternatively, it can be mounted using a hinged bracket or by flange adapter.

• The Lumistar USL 05 LED luminaire fits the following nominal sizes with the corresponding attachment:

Type of fitting	from DN	Hinged bracket	Flanged adapter collar
Circular sightglass fitting	25	+	-
	DIN 28121	40	+
Visual flow indicator	50	+	-
Screw-type sightglass fitting similar to DIN 11851	65	+	+
	80	+	+
	100	+	-
	125	+	-

• Mounting by hinged bracket:

The hinged bracket is intended for mounting the luminaire on the mating flange of a circular sight glass fitting (also on fittings for flow sight glasses) or on the grooved nut in the case of screwed sight glass fittings to DIN 11851.

To do this, the hinged bracket is fixed in place in a blind hole tapped on the relevant bolt pitch circle using the "M6" screw included in the scope of supply.

Alternatively, the hinged bracket can be welded on.

• Mounting with flange adapter:

The flange adapter is mounted on the slotted nut (DIN 11851) by welding or a screwed joint.

• Parameters/Temperature classification:

USL 05-LED Variant	Part no.	Nom. voltage V	Push button	Timer	Replacement parts LED		
					Module	Part no.	
(24 V) 7.5 W	3431.831.00	24 ≈	without	without	24 V	3858.023.00	
(24 V) 7.5 W	3431.832.00	24 ≈	with	without	24 V	3858.024.00	
					Voltage	Socket	
(230 V) 5 W	3540.047.00	230 ~	without	without	230 V	GZ10	3233.029.00
(230 V) 5 W	3541.961.00	230 ~	with	without	230 V	GZ10	3233.029.00



Lumistar Leuchte USL 05-LED

Lumiglas

• Electrical connection:

- Unscrew the glass lens using the special mounting spanner
- Loosen the screws of the LED insert and remove the LED insert using the bolts
- Insert the connection cable into the luminaire and wire to the terminals provided
- Slide the LED insert into the luminaire, at the same time holding back the connecting cable
- Secure the cable entry gland
- Fix the LED insert in place and close the luminaire body with the screwed glass lens

- **Caution:** Avoid looking into the light source – risk of damage to the eyes!

• Replacing LED:

- Switch off power to the luminaire
- Unscrew the glass lens using the special mounting spanner
- Remove the defective LED
- Insert new LED, press in and then lock in place with a short rotation. Make sure the LED is correctly fitted!
- After opening the luminaire the thread of the screwed lens should be regreased (e.g. with AEMA-SOL 6 B made by A.E. Matthes)
- Replace screwed glass lens until it is tight (pressure against O-ring)

• Please note:

Mounting accessories and mounting spanner should be ordered separately, if needed.

• Replacement parts:

- | | |
|---|--------------------------------|
| - O-ring seal (Viton) | Part no.
0862.036.00 |
| - Lamp holder, GZ10 | 1202.024.00 |
| - LED, GZ10, 230 V | 3233.029.00 |
| - LED module, 24 V, without push button | 3858.023.00 |
| - LED module, 24 V, with push button | 3858.024.00 |

• Accessories:

- | | |
|-------------------------------------|-------------|
| - Special spanner to open luminaire | 6816.001.00 |
|-------------------------------------|-------------|

• Maintenance:

- The luminaire should be kept clean
- Only original replacement parts should be used

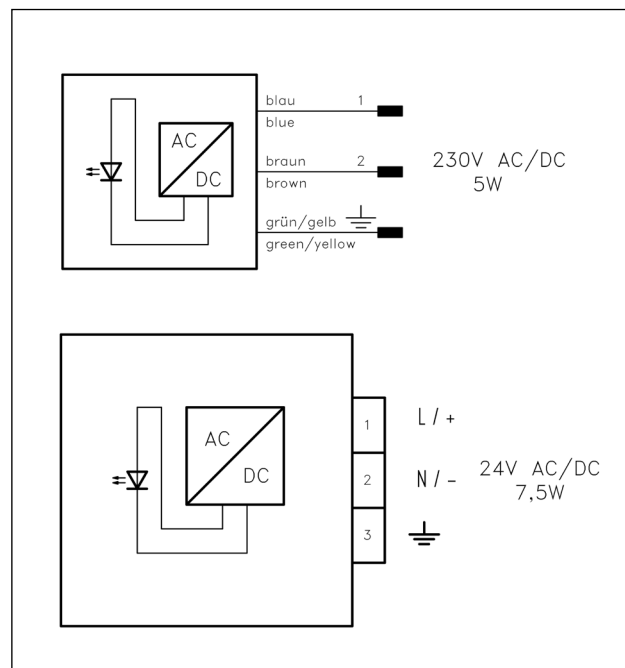
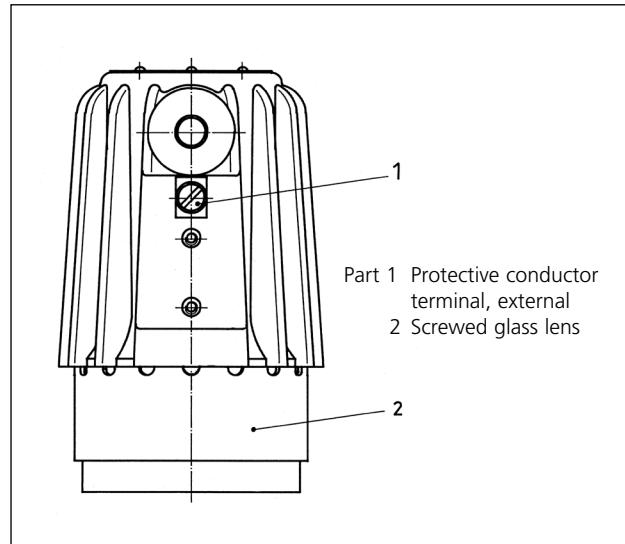

Wiring diagram Lumistar luminaire USL 05-LED