

Installation and Operating Instructions **CE**

Lumistar Luminaire ESL 51-LED, Stainless Steel

ESL 51-LED-HK: with clip for SW I (sight glass wiper)
 ESL 51-LED-KS: with hinged bracket for general applications
 ESL 51-LED-B: special sterile version for flange attachment,
 for fitting over flanges, collars, etc.

Important, please note:

Sight glass luminaires are purpose-designed and are intended solely for mounting on sight glass fittings. Under no circumstances should a luminaire be utilised as a substitute for the cover flange or the complete sight glass flange fitting or used on its own to close a vessel port.

These luminaires must always be installed, connected and serviced by persons who have been specially trained and are authorised to do this work.

Caution: Avoid looking into the light source – risk of damage to the eyes!

Electrical data – general

- The voltage, output and protection class are specified on the type plate
- Excess voltage will cause the luminaire to fail prematurely

General operating conditions:

- Independent of internal pressure/vacuum in the vessel
- Max. admissible ambient temperature at the cable gland: 50°C

Mechanical installation:

In the case of the circular sight glass fitting and flow sight glass the luminaire is attached by the hinged bracket to the counter-flange; with the screw-type sight glass fitting it is mounted on the slotted cover nut.

When using the Lumiglas sight glass wiper unit SW I, the luminaire is attached to the wiper by a clip.

Lumistar ESL 51-LED luminaires fit the following nominal sizes:

- Circular sight glass fitting to DIN 28120: from DN 25
- Circular sight glass fitting to DIN 28121: from DN 40
- Sight glasses in flow indicators: from DN 25
- Screw-type sight glass fittings similar to DIN 11851: from DN 40

Electrical connection:

- The connecting cable (3 m) comes ready connected to the luminaire through the cable entry gland. The luminaire is internally wired and ready for use.

Voltage type: AC/DC

Operating voltage: 24 V
 Output: 2.5 W

Maintenance:

- The luminaire should be kept clean and free of dust!
- Please use original replacement parts only!

Accessories:

Luminaire attachment, hinged bracket	Part. No. 0527.013.00
Pushbutton	8531.024.00



Lumistar luminaire ESL 51-LED-HK used on a screw-type sight glass fitting with Lumiglas screen wiper unit SW I

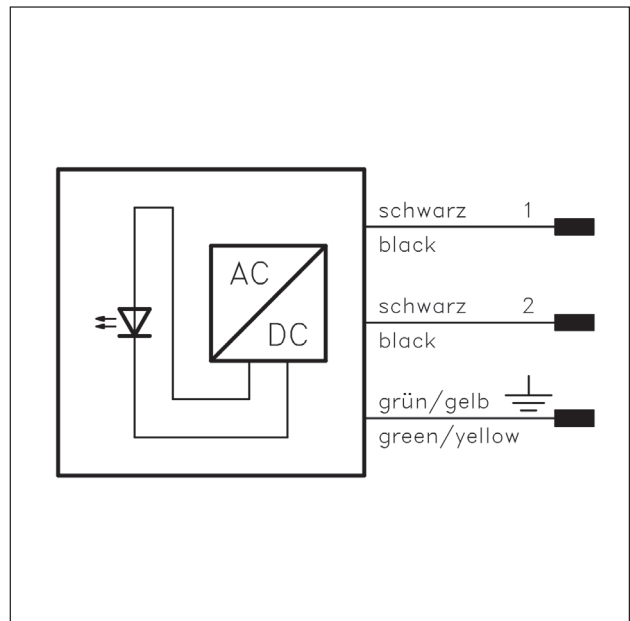

Terminal connection Lumistar luminaire ESL 51-LED-HK

All dimensions in mm unless stated otherwise. Subject to change without prior notice. 06.16